

Thermostatic MIXING VALVE ECO-MIX™

MODEL-554-270-LF Exposed Assembly

__MODEL-554-270-LF 1/2" inlets and outlet

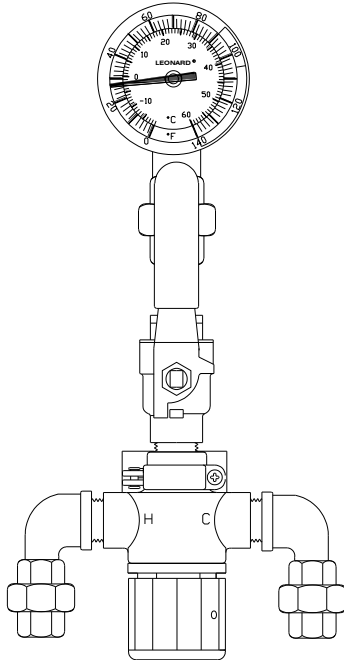

- Lead-Free Bronze body
- Locked temperature adjustment cap (vandal resistant)
- Copper encapsulated thermostat assembly with polymer thermoplastic shuttle
- Stainless steel springs
- Integral check valves on hot and cold inlets
- Minimum Flow: 0.25 GPM (1.9 l/Min) *
- Maximum Pressure: 125 PSI (8.6 BAR)
- Maximum Hot Water temperature: 200°F- (93°C)
- Approach Temperature 5°F (2.8°C) above set point.
- Temperature adjustment range, 90-140°F (32-60°C) **
- Tempered outlet ball valves
- Unions on inlets and outlet
- Color coded dial thermometer (0 to 140°F, -10° to 60°C)
- Bottom inlets, top outlet
- Wall mounting bracket
- Factory assembled and tested

OPTIONS:

__SUFFIX CP - Chrome plated finish

PRESSURE DROP						PSI
5	10	20	30	40	50	
.35	.70	1.4	2.1	2.8	3.4	BAR
3.5	5.5	7.5	9.5	10.5	12	GPM
13	21	28	36	40	45	l/min

* 0.25 GPM minimum flow certified to ASSE 1070



WARNING: This product can expose you to chemicals including lead, which is known to the State of California to cause cancer. For more information, go to www.P65Warnings.Ca.gov

Note: Leonard Valve Company reserves the right of product, or design modifications without notice or obligation.

Engineer's Approval	Job # _____
	Arch/Eng. _____
	Contractor _____
CAUTION! All thermostatic water mixing valves have limitations. They will NOT provide the desired accuracy outside of their flow capacity range. Consult the Flow Capacity Chart and DO NOT OVERSIZE. Minimum flow must be no less than as indicated.	

Certifications:

Valve is ASSE 1017, 1070-2015



Valve is CSA B125.70-15



Valve is CUPC



Valve is Certified to NSF61 thru the ASSE 1070 testing process

Valve is certified to meet Low-Lead requirements of wetted surface area containing less than 0.25% lead by weight. All other fittings and components, the sum total of which comprise the wetted surface of this product, contains, less than one quarter of one percent of lead by weight.



1360 Elmwood Avenue, Cranston, RI 02910 USA

Phone: 401.461.1200 Fax: 401.941.5310

Email: info@leonardvalve.com

Web Site: <http://www.leonardvalve.com>