

INSTALLATION ADJUSTMENT SERVICE NUCLEUS VALVE

IMPORTANT! Provide serial number when ordering parts!!

INSTALLATION

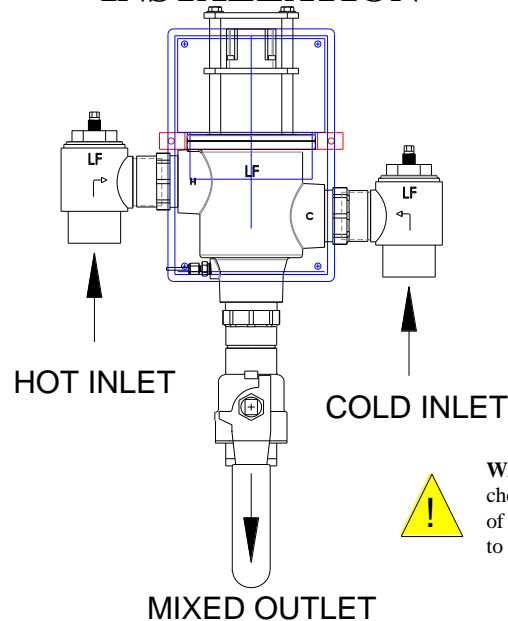

WARNING: This product can expose you to chemicals including lead, which is known to the State of California to cause cancer. For more information, go to www.P65Warnings.Ca.gov

INSTALLATION AND FIELD ADJUSTMENTS ARE THE RESPONSIBILITY OF INSTALLER. READ ALL INSTRUCTIONS PRIOR TO INSTALLATION



- | | |
|--|--|
| <ol style="list-style-type: none"> Leonard Nucleus Valves are factory pre-assembled and tested and include digital mixing valve and controls which function as a system to meet both high and low demand for tempered water. System should be installed at a location where it can easily be cleaned, adjusted or repaired. System supplies must be connected as shown (Hot-left, Cold-right). Exercise caution when soldering. | <ol style="list-style-type: none"> Flush pipes thoroughly after system has been connected. This assembly MUST be piped according to LEONARD'S REQUIRED PIPING METHOD W. Refer to pages 2-4 of this bulletin for correct Setup Instructions. |
|--|--|

Model NV-150-LF – 1¼” Inlets, 1½” Outlet

Model NV-200-LF – 2” Inlets and Outlet

Model NV-300-LF – 3” Inlets and Outlet

Maximum Operating Pressure 125PSI (8.6 BAR) for Hot and Cold Water.

Hot Water Temperature Range: 120° - 180°F (49° - 82°C)

Cold Water Temperature Range: 39° - 80°F (4° - 27°C)

Temperature Adjustment Range: 65° - 180°F (18° - 82°C)

1360 Elmwood Avenue, Cranston, RI 02910 USA

Phone: 401.461.1200 Fax: 401.941.5310

Email: info@leonardvalve.com

Web Site: <http://www.leonardvalve.com>

SETUP INSTRUCTIONS

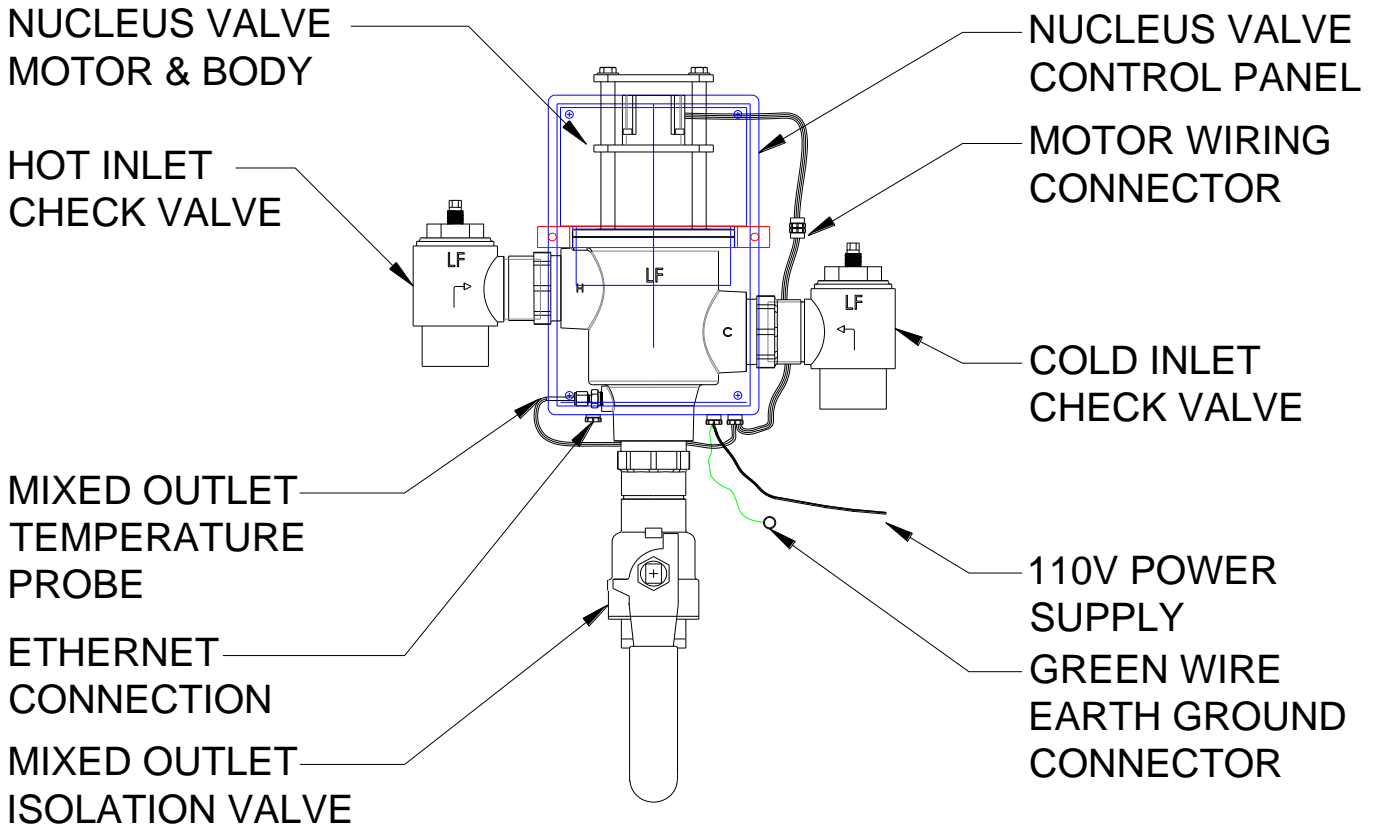

WARNING



The Leonard Nucleus Digital Mixing Valve is an electronically controlled device utilizing DC circuitry. The Green Wire Earth Ground Connector **MUST** be properly grounded to a nearby suitable earth ground prior to connecting the Outlet RTD Probe, Motor Wiring Harness and the Main Unit Power Supply. Installer must follow detailed instructions below to ensure proper operation of valve.

RELAY RATING: 30 V DC, SELV, LPS, or Class 2, 2 Amp MAX, 60W, NO Only

Valve assembly is suitable for indoor use only

Valve outlet must face down and be piped to Method W, see page 31



•NOTE! READ ALL INSTRUCTIONS PRIOR TO INSTALLATION



INSTALLATION INSTRUCTIONS

1. The Nucleus Unit MUST be piped according to a Leonard Required Piping Method W (see page 31).
2. Mount valve body outlet facing down and plumb inlet and outlet connections. DO NOT introduce water to the valve until completion of these instructions.
3. Mount Nucleus Control Box to supplied Mounting Bracket and adjust the tuning screw on the bracket to desired position. Ensure all wiring exiting the box is accessible.
4. Connect Green Wire Earth Ground Connector to suitable nearby earth ground location.
5. Remove compression fitting from left side of the valve outlet. Slide RTD Probe #1 through the compression fitting and insert into the left side of the valve outlet. Tighten compression fitting by hand, and then tighten just 1/8 to 1/4 turn. DO NOT overtighten fitting. See page 30 for more detail.
6. If additional RDT probes and pressure sensors are included, install them at the appropriate locations. If 'IF-RTS' option is included, leave provisions for the RTD probe marked "RETURN" to be installed on the tempered return line (1/2" NPT Connection). Tighten compression fittings by hand, and then tighten just 1/8 to 1/4 turn. DO NOT overtighten fittings. See page 30 for more detail. Plug in pressure sensor harnesses into the pressure sensors.
7. Connect and tighten Motor Wiring Harness, if needed.
8. Open all inlet and outlet check-stops and ball valves to pressurize Nucleus valve.
9. Plug power supply into 110V receptacle. GFCI receptacles are recommended. Installer to follow local electrical codes.
10. Powering Valve Control Box will cause the valve motor to initiate a FULL VALVE SWEEP (End to End), indicating that the motor has traveled 900-1500 Steps. Following the FULL SWEEP, the valve is ready for commissioning and the LED Screen will display the following:
***ERR: 1 EEPROM
Commission Unit***
11. Installer will then press the **ENTER** key which will lead to the following LED screen display
CUR TEMP: XXXF
SET POINT: XXXF
12. Press **ENTER** to adjust SET POINT temperature. Use ▲ ▼ buttons to adjust SET POINT temperature to required outlet temperature. The Nucleus Valve will automatically adjust to new SET POINT, though this does not mean the unit is fully commissioned.



Nucleus Digitally Controlled Mixing Valve User Interface

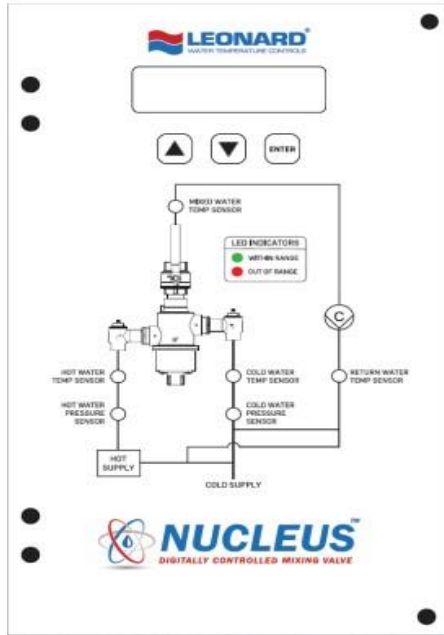

The Nucleus Digitally Controlled Mixing Valve consists of an electronics box that is simplistic in design and has a user interface that is intuitive. The Overlay pictured above is a graphical representation of a typical plumbing system where a Digital Thermostatic Mixing Valve provides mixed hot water to the plumbing system. At key locations on the diagram, there are 6 LED indicators that provide system status either “within range” (Green) or “out of range” (Red) and they are as follows:

Inlet Hot Water Pressure (P1), Inlet Hot Water Temperature (T1), Inlet Cold Water Pressure (P2), Inlet Cold Water temperature (T2), Mixed Water Temperature Sensor (T3), and Return Water Temperature Sensor (T4).

Above the Overlay is a 2 Line, 16 character LED digital display screen, which serves as the User Interface by utilizing a simple 3-button keypad interface: ▲, ▼ and ENTER

On Initial Power up, the valve will go through a full sweep function, which moves the motor its full travel, end-to-end of hot and cold ports of the valve body. This process assigns a numerical value to the distance travelled by the motor, in steps, that will be used in future comparisons to indicate if there is a potential maintenance problem or internal mechanical issue with the components of the valve.

User Screens

Home Screen: Current outlet temperature and Set point temperature



Home Screen: After initial “Full Sweep” the digital display indicates current measured temperature on the mixed outlet of the valve (T3) and shows set point temperature on the line below. **Note:** A large negative value displayed at the **Cur temp** line indicates the sensor is damaged or not properly wired to the main control board. Temperature is easily adjusted by pressing the **ENTER** key and pressing the ▲ and ▼ keys to adjust temperature up or down. When desired value is reached, pressing the **ENTER** key will store the new set point temperature the valve will target and a message stating that the set point has been saved will be displayed. If no new temperature is saved, the screen display will revert back to the Home Screen after approximately 10 seconds and the set point will remain unchanged. Symbols + and – indicate whether the outlet temperature is being adjusted higher (+) or lower (-) by the controller.

Standard Menu: Options on Board/Equipped:

Pressing either the ▲ or ▼ keys will allow a user to scroll through other data points, features and options of the valve and will show the following screens and features in order.

Note: ▼ key was used for this manual’s sequence and should be considered forward direction in the menu. Pressing the ▲ key will reverse the order and can be considered reverse direction.

Menu Screen 1: Inlet Hot Water Temperature



Pressing ▼ 1 time displays **Hot temp: XXX F or C**

This screen displays actual hot water inlet supply temperature as measured at RTD (T1) if the Nucleus is so equipped with the optional inlet temperature sensors.

Note: A large negative value displayed at the **Hot temp** line is an indication that there is no sensor installed to the main control board, the wiring to the main board is improper or the sensor is damaged.

Menu Screen 2: Inlet Cold Water Temperature



Pressing ▼ 2 times displays **Cold temp: XXX F or C**

This screen displays actual cold water inlet supply temperature as measured at RTD (T2) if the Nucleus is so equipped with the optional inlet temperature sensors.

Note: A large negative value displayed at the **Cold temp** line is an indication that there is no sensor installed to the main control board, the wiring to the main board is improper or the sensor is damaged.

Menu Screen 3: Return Water Temperature



Pressing ▼ 3 times displays **Rtrn temp: XXX F or C**

This screen displays actual return water temperature if the Nucleus is equipped with the optional Return Temperature RTD, value as measured on (T4).

Note: A large negative value displayed at the **Rtrn temp** line is an indication that there is no sensor installed to the main control board, the wiring to the main board is improper or the sensor is damaged.

Menu Screen 4: Inlet Hot Water Pressure



Pressing ▼ 4 times displays **Hot psi: XX.XX**

This is a measurement of the inlet hot water supply pressure (PSI) available to the mixing valve if the Nucleus is so equipped with the optional Pressure Sensor (P1).

Note: A large negative value displayed at the **Hot psi** line is an indication that there is no sensor installed to the main control board, the wiring to the main board is improper or the sensor is damaged.

Menu Screen 5: Inlet Cold Water Pressure



Pressing ▼ 5 times displays **Cold psi: XX.XX**

This indicates of the inlet cold water supply pressure (PSI) available to the mixing valve if the Nucleus is so equipped with the optional Pressure Sensor (P2).

Note: A large negative value displayed at the **Cold psi** line is an indication that there is no sensor installed to the main control board, the wiring to the main board is improper or the sensor is damaged.

Menu Screen 6: Optional Daughter Board



Pressing ▼ 6 times displays **Daughter Brd: N or Y**

This screen indicates whether or not the control box is equipped with a Daughter Board, which is an add-on optional circuit board for the following additional equipment and capabilities:

4 additional Temperature Probes (RTD's) T5, T6, T7, T8, 2 Flow Meters (F1 & F2) and/or 1 additional pressure sensor (P3) which are standard 4-20mA inputs

(See Page 28 for details regarding Daughter Board)

Note: If 'N' is showing for Daughter board, there will be no additional support screens associated with Sensors T5, T6, T7, T8 and F1, F2 and/or P3.

Note: If the Nucleus control box is equipped with a Daughter Board the following will show:



This Menu Screen will be followed by the additional screens associated with the optional equipment that may or may not be incorporated into the Nucleus configuration.

The following additional equipment may be on board:

4 additional Temperature Probes (RTD's) T5, T6, T7, T8, 2 Flow Meters (F1 & F2) and/or

1 additional pressure sensor (P3) which are standard 4-20mA inputs

(See Page 28 for details regarding Daughter Board)

Menu Screen 7: Optional Temperature Probe 5 (T5)



Pressing ▼ 7 times displays **Temp 5: XXX F or C**

This indicates and displays actual temperature as measured on RTD (T5) if the Nucleus is so equipped with the optional temperature sensors.

Note: A large negative value displayed at the **Temp 5** line is an indication that there is no sensor installed to the main control board, the wiring to the main board is improper or the sensor is damaged.

Menu Screen 8: Optional Temperature Probe 6 (T6)



Pressing ▼ 8X displays **Temp 6: XXX F or C**

This indicates and displays actual temperature as measured on RTD (T6) if the Nucleus is so equipped with the optional temperature sensors.

Note: A large negative value displayed at the **Temp 6** line is an indication that there is no sensor installed to the main control board, the wiring to the main board is improper or the sensor is damaged.

Menu Screen 9: Optional Temperature Probe 7 (T7)



Pressing ▼ 9 times displays **Temp 7: XXX F or C**

This indicates and displays actual temperature as measured on RTD (T7) if the Nucleus is so equipped with the optional temperature sensors.

Note: A large negative value displayed at the **Temp 7** line is an indication that there is no sensor installed to the main control board, the wiring to the main board is improper or the sensor is damaged.

Menu Screen 10: Optional Temperature Probe 8 (T8)



Pressing ▼ 10 times displays **Temp 8: XXX F or C**

This indicates and displays actual temperature as measured on RTD (T8) if the Nucleus is so equipped with the optional temperature sensors.

Note: A large negative value displayed at the **Temp 8** line is an indication that there is no sensor installed to the main control board, the wiring to the main board is improper or the sensor is damaged.

Menu Screen 11: Optional Flow Sensor (F1)



Pressing ▼ 11 times displays **Flow 1: XXX**

This indicates and displays actual flow in (GPM) on Flow channel 1 for the optional Daughter Board. See Page 28 for wiring setup.

Note: A large negative value displayed at the **Flow 1** line is an indication that there is no sensor installed to the main control board, the wiring to the main board is improper or the sensor is damaged.

Menu Screen 12:

Additional Optional Flow Sensor (F2) OR Optional Pressure Sensor Input Channel (P3)



Pressing ▼ 12 times displays **Flow 2: XXX or Psi 3: XX.X**

This indicates and displays actual flow in (GPM) on Flow channel 2 for the optional Daughter Board. See Page 28 for wiring setup.

NOTE: This channel can also be configured to accept a Pressure Sensor as an alternate and can be setup in the commissioning menu. See Commissioning Menu.

If this channel is configured to accept a pressure input instead, the Menu Screen will look as follows:



This is an indication of the actual measured value of pressure (PSI) on pressure sensor 3 (P3) if the Nucleus is so equipped with the optional Pressure Sensor (P3).

Note: A large negative value displayed at the **Flow 2** or **Psi 3** line is an indication that there is no sensor installed to the main control board, the wiring to the main board is improper or the sensor is damaged.

Menu Screen 13: Main Power Supply



Pressing ▼ 13 times displays **POWER: 12.88**

This indicates the input supply voltage to the main control board, Volts DC, and should always be at least 12 VDC

Menu Screen 14: Back-up Uninterruptable Power Supply



Pressing ▼ 14X displays **UPS: XX.XX**

If the Nucleus is equipped with an uninterruptable power supply for standby operation in the event of power loss, and there is a loss of primary power to the device, there will be a numerical value in this field and it should be always at least 12 VDC

Menu Screen 15: Building Management System Module



Pressing ▼ 15X displays **BMS Connected: N or Y**

In order for this to be 'Y', or YES, the control box needs the following conditions: The Leonard supplied ProtoCessor needs to be installed on the main Printed Circuit Board. This screen confirms that the protocol converter is communicating with the main PCB. If 'N' is displayed and a ProtoCessor is connected, make sure the module is installed properly.

Menu Screen 15: Building Management System Module

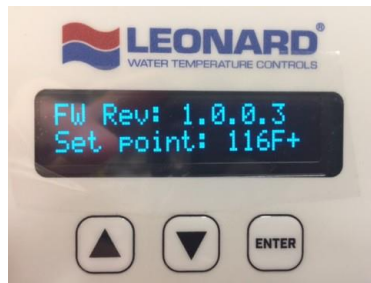

Pressing ▼ 16 times displays **FW Rev: X.X.X.X**

This screen shows the current version of Firmware loaded into the Nucleus processor. It may be used for reference and troubleshooting.

Home Screen: Current outlet temperature and Set point temperature



Pressing ▼ 17 times displays **Cur Temp: XXX F or C**

The user is returned to the 'Home Screen' which displays current temperature as measured on valve outlet (T3) and the set point temperature on the line below.

Note: A large negative value displayed at the **Cur temp** line indicates the sensor is damaged or not properly wired to the main control board.

Note: Pressing the ▲ key will reverse the order previously shown and allow the user to scroll through the above menu items in reverse order.

Nucleus Digitally Controlled Mixing Valve Commissioning

The commissioning menu on the Nucleus Digitally Controlled Mixing Valve is entered by pressing a sequence of keys on the keypad as a “protected” step as this requires the end-user to be aware of potential changes to the programming and the subsequent associated potential risk to users downstream of the device.

! WARNING: You are about to enter commissioning menu of the Nucleus Digitally Controlled Mixing Valve and adjustments to the mixing valve may result in severe burns, injury and/or death to users downstream of the device if proper safety precautions are not adhered to.

Commissioning the Digital Mixing Valve - Overview

1. To enter the commission menu via panel, push the keys in the following sequence:
▲ ▼ ▲ ▼ ENTER
2. Now in commissioning mode, use **▲** or **▼** keys to scroll through the various adjustable parameters and set points. At each screen pressing the **ENTER** key causes the default value to flash and the value shown can be changed using the **▲ ▼** keys. Once the desired value is displayed, pressing **ENTER** locks in the new value. Continue reading for description and limitations of each parameter.
3. Once all desired values have been entered, scroll to **SAVE** screen using **▲** or **▼** keys and press **ENTER**. Using **▲** or **▼** keys, scroll to ‘**Y**’ and press enter. The values are now saved. The screen should now display the CURRENT and SET POINT temperatures and the panel will begin to indicate if any conditions are in error or alarm state.
4. See page 38 to record all of the commissioned settings.

Commissioning Menu Screen 1: 5V Motor



Initial Screen in commissioning menu is asking whether or not the motor installed is a 5V motor. If the motor is 5V, choose ‘**Y**’. If the motor installed is a 12V, select ‘**N**’.

Commissioning Menu Screen 2: **Temperature Scale**



Pressing ▼ 1 time displays **Min temp**

Initial Screen in commissioning menu requests the scale of temperature measurement in Fahrenheit (F) or Celsius (C)

Commissioning Menu Screen 3: **Minimum System Temperature**



Pressing ▼ 2 times displays **Min temp**

This is minimum temperature as measured on the primary outlet temperature sensor of the Nucleus Mixing Valve RTD (T3). Measured values above this value will cause an alarm condition that will switch a relay to Normally Opened (See Page 27, Alarm Relay Detail). Default value is 65°F.

Commissioning Menu Screen 4: **Maximum Outlet Temperature**



Pressing ▼ 3 times displays **Max temp**

This is maximum temperature as measured on the primary outlet temperature sensor of the Nucleus Mixing Valve RTD (T3). Measured values above this value will cause an alarm condition that will switch a relay to Normally Opened (See Page 27, Alarm Relay Detail). Default value is 130°F.

Commissioning Menu Screen 5: Error Time to Make Live



Pressing ▼ 4 times displays **Err TTML**

This indicates the **TIME TO MAKE LIVE**, which is an elapsed time in seconds as to when an actual error will be identified by the processor (e.g. low inlet supply pressure) and then subsequently recognized as a true error and displayed on the LCD screen. The error must exist for at least this minimum time before being considered a true error. The default value is 15 seconds.

Commissioning Menu Screen 6: Error Time to Live



Pressing ▼ 5 times displays **Err TTL**

This indicates **TIME TO LIVE**, which is a time in seconds and starts as soon as **Err TTML** has elapsed. An error that exists past both TTML and TTL will require user recognition to clear error from screen by pressing **ENTER**. If the problem corrects itself during the elapsing TTL time, the Error will be automatically removed from the display on the user interface and therefore does not exist in memory. Default time is 60 seconds.

Commissioning Menu Screen 7: Auxiliary Flow Sensor #2



Pressing ▼ 6 times displays **Aux2 flow: N or Y**

This indicates whether or not the configurable auxiliary channel, if utilized, is a 2nd flow meter or a 3rd pressure sensor supplied with the Nucleus unit. Select 'Y' if a flow meter is used or 'N' if a pressure sensor is used. See Page 28 for proper wiring configuration

Commissioning Menu Screen 8: Shuttle Full Sweep



Pressing ▼ 7 times displays **Commissioning Full sweep: N or Y**

This feature allows the user to manually 'sweep' the shuttle inside the main valve body from full hot to full cold position in order to verify mechanical integrity of the device, and verify that the valve is traveling the entire range of its expected travel or operating range. To initiate a full sweep, press **ENTER** and change the flashing value to 'Y' (yes) and press **ENTER** to confirm.

Commissioning Menu Screen 9:

Minimum Alarm Temperature for Temperature Sensor #5

Note: There are four (4) additional RTD temperature probe provisions (T5, T6, T7, T8) if the Nucleus is equipped with an optional Daughter Board. Please see Screen 6 (Page 7) from Options/Equipped section above and if Daughter Board is showing 'Y' (Yes), then these temperature probes should be configured, if they are being utilized.



Pressing ▼ 8 times displays **Commissioning Temp 5 min: 32F**

This is the minimum temperature for RTD probe T5. Any temperature below this setting at T5 will trigger an error message. Default setting is 32°F.

Commissioning Menu Screen 10:
Maximum Alarm Temperature for Temperature Sensor #5



Pressing ▼ 9 times displays **Commissioning Temp 5 max: 185F**

This is the maximum temperature for RTD probe T5. Any temperature above this setting at T5 will trigger an error message. Default setting is 185°F

Commissioning Menu Screen 11:
Minimum Alarm Temperature for Temperature Sensor #6



Pressing ▼ 10 times displays **Commissioning Temp 6 min: 32F**

This is the minimum temperature for RTD probe T6. Any temperature below this setting at T6 will trigger an error message. Default setting is 32°F.

Commissioning Menu Screen 12:
Maximum Alarm Temperature for Temperature Sensor #6



Pressing ▼ 11 times displays **Commissioning Temp 6 max: 185F**

This is the maximum temperature for RTD probe T6. Any temperature above this setting at T6 will trigger an error message. Default setting is 185°F

Commissioning Menu Screen 13:

Minimum Alarm Temperature for Temperature Sensor #7



Pressing ▼ 12 times displays **Commissioning Temp 7 min: 32F**

This is the minimum temperature for RTD probe T7. Any temperature below this setting at T7 will trigger an error message. Default setting is 32°F

Commissioning Menu Screen 14:

Maximum Alarm Temperature for Temperature Sensor #7



Pressing ▼ 13 times displays **Commissioning Temp 7 max: 185F**

This is the maximum temperature for RTD probe T7. Any temperature above this setting at T7 will trigger an error message. Default setting is 185°F

Commissioning Menu Screen 15:

Minimum Alarm Temperature for Temperature Sensor #8



Pressing ▼ 14 times displays **Commissioning Temp 8 min: 32F**

This is the minimum temperature for RTD probe T8. Any temperature below this setting at T8 will trigger an error message. Default setting is 32°F

Commissioning Menu Screen 16:

Maximum Alarm Temperature for Temperature Sensor #8



Pressing ▼ 15 times displays **Commissioning Temp 8 max: 185F**

This is the maximum temperature for RTD probe T8. Any temperature above this setting at T8 will trigger an error message. Default setting is 185°F

THERMAL DISINFECTION

WARNING: The Nucleus Digitally Controlled Mixing Valve is equipped with the ability to program the valve to move to full hot position, which will allow ONLY high temperature hot supply water to enter the device and subsequently deliver that high temperature water downstream of the device. There is inherent risk in this procedure and it is a feature which allows the user to 'Disinfect' the plumbing system downstream of the device.

Commissioning Menu Screen 17: Thermal Disinfection



Pressing ▼ 16 times displays **Commissioning Disinfect: N or Y**

BEFORE THIS MODE IS ENGAGED, AN AUTHORIZED USER MUST BE AWARE OF THE POTENTIAL RISKS TO END USERS DOWNSTREAM OF THIS DEVICE, AND MUST ALSO MAKE PROVISIONS TO PUT SAFETY MEASURES IN PLACE DURING THE DISINFECTION STAGE TO ENSURE USER SAFETY.

SEVERE BURNS, SEVERE INJURY AND/OR EVEN DEATH MAY OCCUR IF SUCH PROVISIONS ARE NOT IN PLACE WHEN SELECTING 'Y' ON THIS MENU!



Before a disinfection cycle is initiated, the **MIN** and **MAX** settings **MUST** be changed to accommodate higher outlet temperatures. **MIN** setting should be set to the minimum desired disinfection temperature. **MAX** setting should be changed to the maximum desired disinfection temperature. After the first minute of disinfection, an error will be triggered if the outlet temperature is below the **MIN** or above the **MAX** settings, which will automatically end the cycle.

SEVERE BURNS, SEVERE INJURY AND/OR EVEN DEATH MAY OCCUR IF SUCH PROVISIONS ARE NOT IN PLACE WHEN SELECTING 'Y' ON THIS MENU!



Once 'Y' (yes) is chosen, the authorized user will then be prompted to enter the desired disinfection time, adjustable in 15 minute increments, up to 12 hours. Choose the desired time and press **ENTER** to start the timer. Extreme care must be taken during the disinfection process! Disinfection can be cancelled at anytime by pressing the **ENTER** Key.



Once the disinfection cycle has ended, the valve will enter **COOL DOWN** mode and go back to its last position before disinfection was engaged. The screen will display the current outlet temperature. Cool down can be a lengthy process, as water will need time to cool via radiation. Provisions should be made to manually “dump” water from the loop if a faster cool down time is desired. ***SEVERE BURNS, SEVERE INJURY AND/OR EVEN DEATH MAY OCCUR IF SAFETY PROVISIONS ARE NOT IN PLACE WHEN MANUALLY DUMPING HIGH TEMPERATURE WATER.***



Controller will display **MIN** screen setting once **COOL DOWN** is complete. Change the **MIN** and **MAX** parameters to their previous values if system disinfection has been adequately implemented.

Commissioning Menu Screen 18: Manually Adjust Motor



Pressing ▼ 17 times displays **Commissioning Adj motor: N** or **Y**

SEVERE BURNS, SEVERE INJURY AND/OR EVEN DEATH MAY OCCUR IF SAFETY PROVISIONS ARE NOT IN PLACE WHEN MANUALLY ADJUSTING THE MOTOR POSITION! THIS ACTION SHOULD ONLY BE PERFORMED BY AUTHORIZED PERSONNEL

This feature allows the user to manually move the motor to ensure that it is mechanically connected, mechanically sound, and moving properly with no mechanical binding. When “Y” is selected, the motor position is only being controlled by the authorized user and the screen will display the current position of the motor. Pressing ▲ will move the shuttle to allow more hot water into the valve, while pressing ▼ will move the shuttle to allow more cold water into the valve. To exit this mode, press the **ENTER** key. Once this mode has been exited, the valve will revert back to its standard operation.

Commissioning Menu Screen 19: Erase Commissioned Settings



Pressing ▼ 18 times displays **Commissioning Erase EEPROM: N** or **Y**

SEVERE BURNS, SEVERE INJURY AND/OR EVEN DEATH MAY OCCUR IF SAFETY PROVISIONS ARE NOT IN PLACE WHEN ERASING COMMISSIONED VALUES! THIS ACTION SHOULD ONLY BE PERFORMED BY AUTHORIZED PERSONNEL

This feature allows for the user to erase the Electrically Erasable Programmable Read Only Memory (EEPROM). Entering ‘Y’ will decommission the controller and return it back to factory settings. Once decommissioned the controller will no longer display or send errors to the Building Management System and alarms will no longer be triggered. These features will be inactive until the controller is re-commissioned.

Commissioning Menu Screen 20: Save Commissioned Values



Pressing ▼ 19 times displays **Commissioning Save: N or Y**

This feature will save by selecting 'Y' all commissioning menu settings if they have been altered. Selecting 'N' will not save any altered values and will not commission the controller if it has not been commissioned. Selecting 'N' will also exit commissioning mode and the home screen will then be displayed.

Commissioning Menu Screen 21: Exit Commissioning Mode



Pressing ▼ 20 times displays **Commissioning Exit: N or Y**

This feature will allow users to exit the commissioning menu or continue by selecting. Selecting 'Y' will exit commissioning mode without saving any changes made to the commissioning values will then be displayed. Selecting 'N' will keep the control box in the commissioning menu.

Nucleus Digitally Controlled Mixing Valve Error Codes

Error codes are displayed on LCD screen once TTML has been exceeded. Errors must be manually cleared by pressing ENTER when TTL time has elapsed and the error condition has not been corrected. Error codes below are listed in order of importance to valve and system performance.

ERROR CODE	CAUSE	ACTION
ER1	Full sweep value less than 90% of commissioned value. This is likely due to debris inside of the valve.	Service internals of mixing valve and clean or replace parts. See page 34 for complete service instructions
ERPR	Inlet pressure differential greater than 10%	Investigate cause of pressure differential
ERT3OS	Outlet temperature probe disconnected from controller, not properly installed to controller, or broken.	Check wired connection to controller and confirm proper configuration (see page 28 for wiring diagram). Replace probe if broken
ERT1OS	Inlet hot water temperature probe disconnected from controller, not properly installed to controller, or broken.	Check wired connection to controller and confirm proper configuration (see page 28 for wiring diagram). Replace probe if broken
ERT3+	Outlet temperature greater than 5°F above set point	Investigate cause
ERT1+	Inlet hot water temperature is above 185°F	Investigate cause of hot water temperature being too high. Check hot water source
ERT1-	Inlet hot water temperature is below set point and is too cold	Investigate cause of hot water temperature being too low. Check hot water source
ERT3-	Outlet temperature greater than 5°F below set point	Investigate cause
ERT4OS	Return water temperature probe disconnected from controller, not properly installed to controller, or broken.	Check wired connection to controller and confirm proper configuration (see page 28 for wiring diagram). Replace probe if broken
ERT2OS	Inlet cold water temperature probe disconnected from controller, not properly installed to controller, or broken.	Check wired connection to controller and confirm proper configuration (see page 28 for wiring diagram). Replace probe if broken
ERT4+	Return water temperature greater than set point temperature	Investigate cause
ERT4-	Return water temperature more than 20°F below set point temperature	Investigate cause
ERT2+	Cold water temperature greater than set point temperature	Investigate cause

ERP1OS	Inlet hot water pressure sensor disconnected from harness or controller, not properly installed to controller or broken	Ensure sensor and harness are properly connected. Check wired connection to controller and confirm proper configuration (see page 28 for wiring diagram). Replace probe if broken
ERP2OS	Inlet cold water pressure sensor disconnected from harness or controller, not properly installed to controller or broken	Ensure sensor and harness are properly connected. Check wired connection to controller and confirm proper configuration (see page 28 for wiring diagram). Replace probe if broken
ERP1+	Inlet hot water pressure is greater than 125 PSI	Investigate cause. Valve and related fittings are rated up to 125 PSI working pressure
ERP1-	Inlet hot water pressure is less than 40 PSI	Investigate cause
ERP2+	Inlet cold water pressure is greater than 125 PSI	Investigate cause. Valve and related fittings are rated up to 125 PSI working pressure
ERP2-	Inlet cold water pressure is less than 40 PSI	Investigate cause
ERT5OS	Optional temperature probe (5) disconnected from controller, not properly installed to controller, or broken.	Ignore error if no probe is present. Check wired connection to controller and confirm proper configuration (see page 28 for wiring diagram). Replace probe if broken
ERT5+	Temperature at probe (5) above configured maximum temperature	Investigate cause
ERT5-	Temperature at probe (5) below configured minimum temperature	Investigate cause
ERT6OS	Optional temperature probe (6) disconnected from controller, not properly installed to controller, or broken.	Ignore error if no probe is present. Check wired connection to controller and confirm proper configuration (see page 28 for wiring diagram). Replace probe if broken
ERT6+	Temperature at probe (6) above configured maximum temperature	Investigate cause
ERT6-	Temperature at probe (6) below configured minimum temperature	Investigate cause
ERT7OS	Optional temperature probe (7) disconnected from controller, not properly installed to controller, or broken.	Ignore error if no probe is present. Check wired connection to controller and confirm proper configuration (see page 28 for wiring diagram). Replace probe if broken

ERT7+	Temperature at probe (7) above configured maximum temperature	Investigate cause
ERT7-	Temperature at probe (7) below configured minimum temperature	Investigate cause
ERT8OS	Optional temperature probe (8) disconnected from controller, not properly installed to controller, or broken.	Ignore error if no probe is present. Check wired connection to controller and confirm proper configuration (see page 28 for wiring diagram). Replace probe if broken
ERT8+	Temperature at probe (8) above configured maximum temperature	Investigate cause
ERT8-	Temperature at probe (8) below configured minimum temperature	Investigate cause
ERF1OS	Optional flow sensor (1) disconnected from controller, not properly installed to controller, or broken.	Ignore error if no sensor is present. Check wired connection to controller and confirm proper configuration (see page 28 for wiring diagram). Replace probe if broken
ERF2OS	Optional flow sensor (2) disconnected from controller, not properly installed to controller, or broken.	Ignore error if no sensor is present. Check wired connection to controller and confirm proper configuration (see page 28 for wiring diagram). Replace probe if broken
ERP3OS	Optional pressure sensor (3) disconnected from harness or controller, not properly installed to controller, or broken.	Ignore error if no sensor is present. Ensure sensor and harness are properly connected. Check wired connection to controller and confirm proper configuration (see page 28 for wiring diagram). Replace probe if broken
ERCOMM	Communication between ProtoCessor and main PCB is no longer active	Ensure proper connection between ProtoCessor and main PCB
ERDM+	Outlet temperature above configured maximum outlet temperature	Investigate Cause
ERDM-	Outlet temperature below configured minimum outlet temperature	Investigate Cause
EREE	EEPROM is blank or corrupt	Commission controller. See Commissioning Section of this manual

ALARM RELAY DETAIL

SECTION DETAIL MASTER PCB

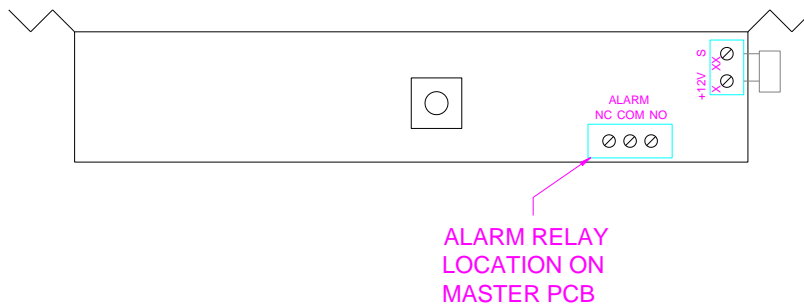

The Nucleus Electrical Control Board has one Alarm Relay Circuit. See Master PCB location above. The alarm relay is rated for the following:

30 Volts DC, 2A Max, 60W, NO Only, SELV, LPS or Class 2

The alarm relay is only activated based on input from the primary RTD temperature probe on the mixed water outlet (T3). The alarm has a preset default **MIN (65°F)** and **MAX (130°F)** in the commissioning menu, and it will activate on measured temperature values of T3 above or below these **MIN / MAX** values. The above values are user adjustable and programmable in the commissioning menu. See **COMMISSIONING** section in this manual, starting on page 13.

Once alarm has been triggered, the error must be manually cleared from the LCD screen by pressing **ENTER**. If alarm condition is still present, the **TTML** (page 15) begins and alarm is re-triggered after **TTML** has elapsed. This process can continue until outlet temperature is within the **MIN / MAX** parameters. The alarm will be de-activated as soon as the measured temperature value at T3 returns to a measured value between **MIN** and **MAX**.

When in a non-alarm state, the relay is in a **Normally Closed (NC)** position. When the alarm is triggered, the relay switches to a **Normally Opened (NO)** position.

MASTER PCB DETAILS

The Primary PCB for this device comes with the following connectivity:

1. Linear motor connection for valve motion.
2. Four standard temperature input channels – T1, T2, T3, T4 – all are 3-wire RTD connection types.
3. Two standard pressure input channels – P1 & P2

The Primary PCB also has the ability to receive a plug-in processor for standard industry protocols (6 native on board) and communication to a Building Management System via Ethernet or RS-485.

BOARD WIRING DIAGRAMS

WIRING KEY

MOTOR WIRING		PRESSURE SENSOR	RTD TEMPERATURE PROBE	FLOW METER
FROM MOTOR TO CONNECTOR	FROM BOARD TO CONNECTOR			
M-1 = RED	M-1 = RED	P#-1 = RED = +5V	T#-1 = WHITE = NEG	F#-1 = BLACK = SIG
M-2 = RED / WHITE	M-2 = WHITE	P#-2 = BLUE = SIG	T#-2 = BLACK = SIG	F#-2 = RED = +12V
M-3 = GREEN	M-3 = GREEN	P#-3 = BLACK = GND	T#-3 = BLACK = POS	
M-4 = GREEN / WHITE	M-4 = BLUE			

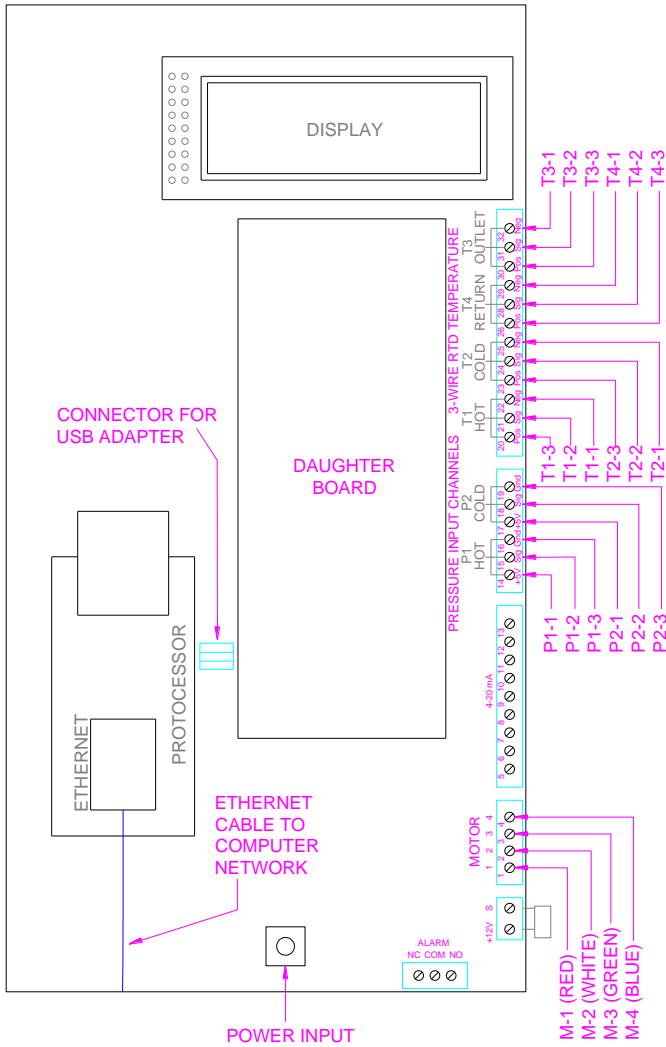

MASTER PRINTED CIRCUIT BOARD WIRING DIAGRAM

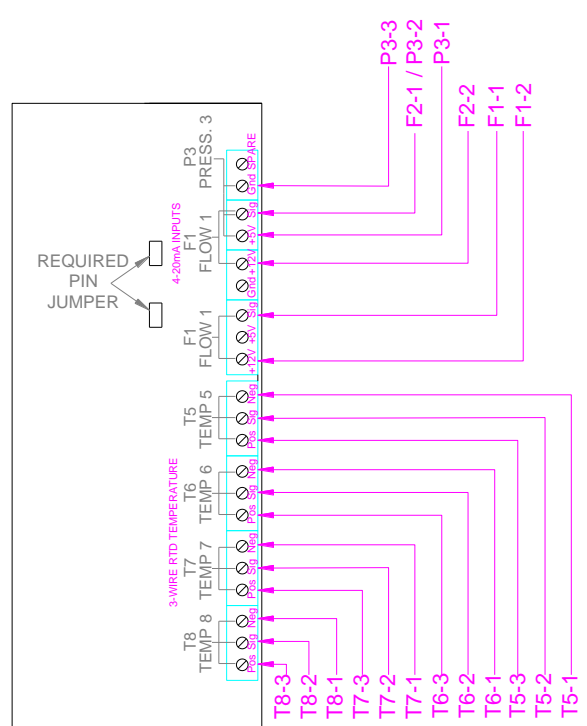

DAUGHTER PRINTED CIRCUIT BOARD WIRING DIAGRAM

AUXILLARY TEMPERATURE PROBES, PRESSURE SENSOR, AND FLOW METERS

DAUGHTER PCB DETAILS

The Daughter PCB is an "option card" and will plug into the primary PCB if required and comes with the following connectivity:

1. Four additional temperature input channels – T5, T6, T7, T8 – all are 3-wire RTD connection type
2. One channel suitable for flow meter – F1
3. One channel suitable for flow meter – F2 or pressure sensor – P3

•SEE ABOVE FOR WIRING DETAILS•

SENSOR TROUBLESHOOTING AND REPLACEMENT

When a sensor is disconnected or no longer in proper working condition, an error message is displayed on the controller (see complete error list starting on page 24). If this sensor is on the master printed circuit board (PCB) then the error will be accompanied by a flashing red LED light on the overlay.

TURN OFF POWER TO THE NUCLEUS CONTROL BOX BEFORE TROUBLESHOOTING OR REPLACING ANY WIRES AND SENSORS. USE ELECTROSTATIC DISCHARGE SAFE TOOLS WHEN WORKING INSIDE OF THE CONTROL BOX!

1. Determine if the sensor is truly broken and not a simple disconnection. Identify the appropriate sensor wires inside of the control box (see wiring diagram on page 28). Check the connection by pulling gently on the wire, best done with needle nose pliers. If the wire can be easily removed from the connector, reinstall and tighten connection with small flathead screwdriver. For pressure sensors ensure that the sensor and wire harness are properly connected as well.
2. If the sensor is properly connected to the controller and the condition persists, then the sensor needs to be replaced. Identify the appropriate sensor wires inside of the control box (see wiring diagram on page 28). Using an flathead screwdriver, loosen the connections between the board and wires. Remove the wires from the connectors.
3. Remove the disconnected wires from the control box. Begin by loosening the cable gland nut on the bottom of the box. Motor wires, T1, T2, T3, T4, P1, P2 wires run through the right-side cable gland, while all other sensors run through the left-side cable gland. Open the cable sleeve and fully remove the defective wires.
4. Shut down hot, cold and outlet ball valves and depressurize the pipes. Remove the defective sensor from the piping and install new sensor in its place. For RTD probes new compression fittings are required. Do not overtighten compression nuts before re-pressurizing valve (See Page 30). Replacement pressure sensors will also include a new harness.
5. Snake new sensor wires through the cable gland. Install replacements wires to their corresponding connectors on the PCB. Refer to wiring diagram on page 28 for the correct configuration.
6. Bundle any loose wires from the new sensor and place into the cable sleeve. Place end of the cable sleeve into the cable gland and tighten the gland nut to secure the sleeve in place. Take care to not put excess strain on the end of the sensor's wires.
7. Open hot, cold and outlet ball valves to pressurize valve. Introduce power to the Nucleus control box and confirm that the replacement sensor is providing proper feedback and data.

INSTALLING AND REPLACING TEMPERATURE PROBES

The RTD temperature probes used with Nucleus assemblies are simple to install. On the valve body the temperature probe is connected to the valve with a $\frac{1}{4}$ " MNPT x $\frac{1}{8}$ " compression fitting. The remaining temperature probes, if present, are installed into the pipe using a $\frac{1}{2}$ " MNPT x $\frac{1}{8}$ " compression fitting. Teflon tape and a small amount of thread sealant should be used on the NPT side of the fittings. The ferrule, installed with the cone facing down, then sits on the top of the compression inlet. The compression nut is then put over the ferrule and tightened slightly, just enough to hold the ferrule in place. The RTD temperature probe is then inserted through the entire fitting until the end of the probe reaches approximately the center of the desired measured water stream. Finally, the compression nut is tightened by hand to "hand-tight" plus $\frac{1}{8}$ to $\frac{1}{4}$ turn with an adjustable or open end wrench. Use caution not to overtighten the fitting and only tighten until dripping stops.

In some instances, it may be easier to loosely install the probe into the compression fitting and then installing the assembly a single piece.

NOTE: if overtightened, leaks are probable and the entire RTD and compression fitting must be replaced!



INSTALLATION OF COMPRESSION FITTING AND OUTLET RTD PROBE ON 2" NUCLEUS VALVE BODY

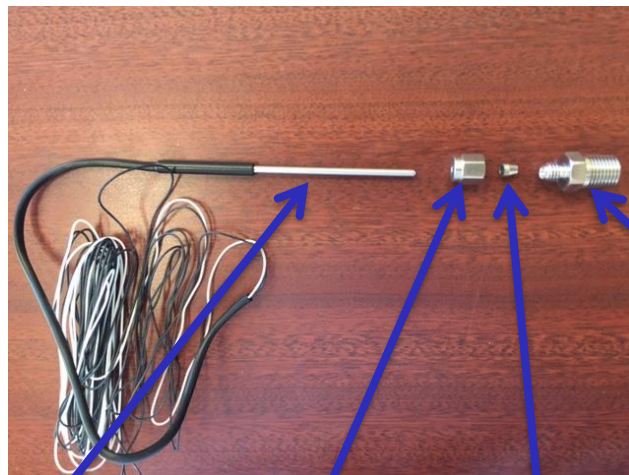

$\frac{1}{4}$ " NPT x Compression Fitting

RTD Probe with
10' Lead Wire

Compression Nut

Ferrule

REQUIRED PIPING METHOD W

PIPING METHOD W

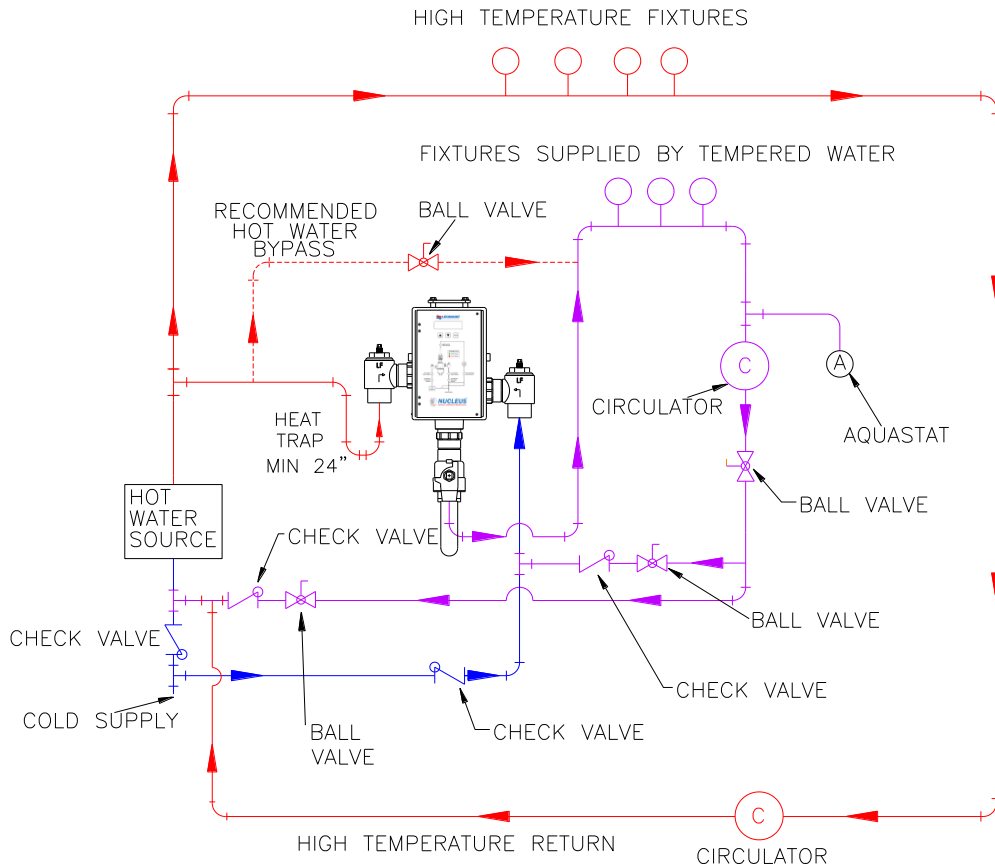

NOTE:

FOR MULTIPLE TEMPERED LOOPS, A BALANCING VALVE AND CHECK VALVE MUST BE INSTALLED ON EACH LOOP AFTER TEMPERED FIXTURES

Leonard Nucleus Digital Mixing Valves are simple in design and may be easily cleaned, adjusted and repaired. If the installation is accessible, servicing may be completed without disconnecting the valves.

NOTE: Leonard Nucleus Digital Mixing Valves must be regularly maintained to provide best performance. Frequency of cleaning depends on quality of local water conditions and usage. See Maintenance Guide and Record MGR-1000

TROUBLESHOOTING INSTRUCTIONS

Note: Provide serial number when ordering parts for each valve!

TROUBLESHOOTING	NV150LF/NV200LF	NV300LF
1. Leaks at stem.	Repair Kit 1/NV	Repair Kit 1/NV3
2. Leak between valve cover and base.		
3. Valve delivers either all hot or all cold water, or will not mix consistently.	Repair Kit R/NV	Repair Kit R/NV3
4. Hot water by-pass into cold line(or cold into hot).	Repair Kit 2/200C	
5. Supplies cannot be shut off completely. Supplies leak at checkstop bonnets.		N/A

NV150 / NV200	NV300	KIT TYPE	INCLUDES
KIT R/NV	KIT R/NV3	COMPLETE REPAIR	1 - 8
KIT 1/NV	KIT 1/NV3	O-RING	1 - 5

#10 cover assembly includes

- Cover, plates
- Motor
- Stem
- O-rings
- Shuttle

All fully assembled

See picture #4 on page 34

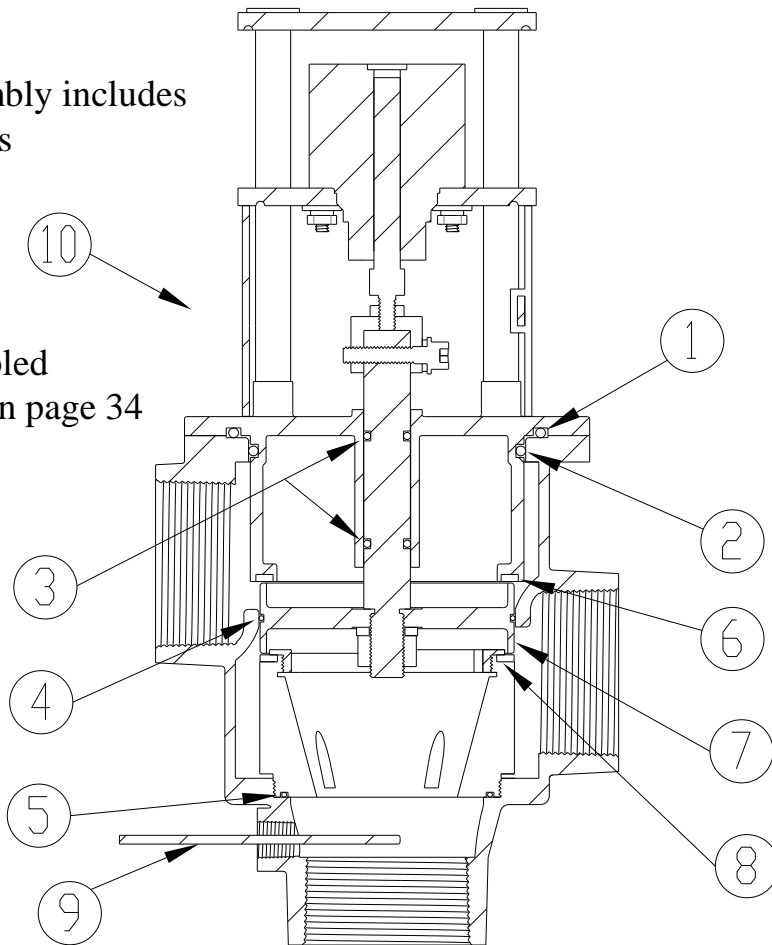

ITEM #	DESCRIPTION	QTY.	NV150 / NV200	NV300
1	O-RING, COVER	1	KIT 1/NV, KIT R/NV	KIT 1/NV3, KIT R/NV3
2	O-RING, COVER	1	KIT 1/NV, KIT R/NV	KIT 1/NV3, KIT R/NV3
3	O-RING, STEM	2	KIT 1/NV, KIT R/NV	KIT 1/NV3, KIT R/NV3
4	O-RING, SHUTTLE	1	KIT 1/NV, KIT R/NV	KIT 1/NV3, KIT R/NV3
5	O-RING, SLEEVE	1	KIT 1/NV, KIT R/NV	KIT 1/NV3, KIT R/NV3
6	SEAT, HOT SIDE	1	KIT R/NV	KIT R/NV3
7	SHUTTLE	1	KIT R/NV	KIT R/NV3
8	SEAT, COLD SIDE	1	KIT R/NV	KIT R/NV3
9	THERMOCOUPLE AND FITTING	1	803200	803200
10	COVER ASSEMBLY	1	808101	808102

NV-150-LF, 1-1/4" CHECKS

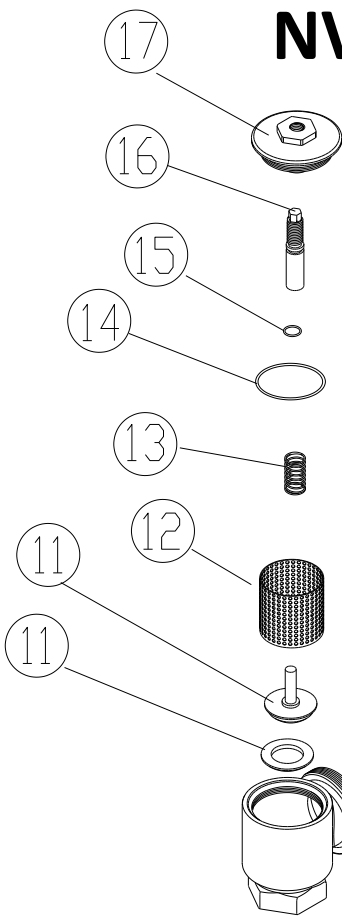

KIT	DESCRIPTION	INCLUDES
KIT 4/984	REBUILD KIT	11-15

ITEM #	DESCRIPTION	QTY.	PART # / KIT #
11	LOWER STEM & PACKING	2	KIT 4/984
12	SCREEN	2	KIT 4/984
13	SPRING,CHECK	2	KIT 4/984
14	O-RING, COVER	2	KIT 4/984
15	O-RING, UPPER STEM	2	KIT 4/984
16	STEM, UPPER CHECK	2	1761
17	CHECK BONNET	2	1786
18A	SWIVEL, SERIAL #S NV1500001 TO NV15003665V	2	04/125 RF
18B	SWIVEL, SERIAL #S NV15003675V AND ABOVE	2	8097
19	SWIVEL NUT	2	09/125 RF

NV-200-LF, 2" CHECKS

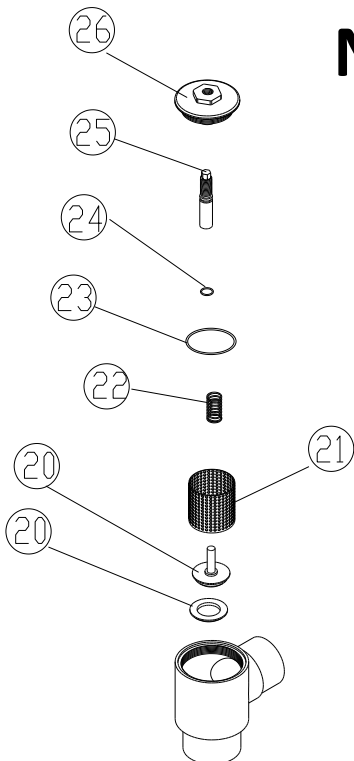

KIT	DESCRIPTION	INCLUDES
KIT 2/200/C	REBUILD KIT	20-24

ITEM #	DESCRIPTION	QTY.	PART # / KIT #
20	LOWER STEM & PACKING	2	KIT 2/200/C
21	SCREEN	2	KIT 2/200/C
22	SPRING,CHECK	2	KIT 2/200/C
23	O-RING, COVER	2	KIT 2/200/C
24	O-RING, UPPER STEM	2	KIT 2/200/C
25	STEM, UPPER CHECK	2	4727
26	CHECK BONNET	2	4723

REMEMBER! THIS IS A CONTROL DEVICE WHICH MUST BE CLEANED AND MAINTAINED ON A REGULAR BASIS (SEE MAINTENANCE GUIDE AND RECORD)

SERVICING INSTRUCTIONS

WARNING: Before servicing Nucleus series valves, be sure to shut down inlet hot, cold and outlet water supplies and power down the Nucleus control box. Failure to do so could result in damage to the control box and could cause injury and/or death to the service technician.

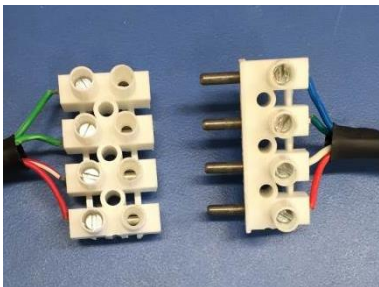

1. Disconnect Motor Connectors.



5. Turn the cover assembly on its side. While securing the hex-coupling under the motor mounting plate, remove the nut, lock washer and shuttle from the control stem.

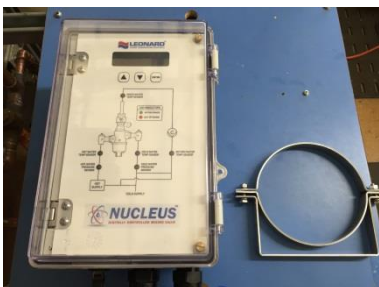

2. If the control box is mounted to the mixing valve, remove it along with the mounting bracket. Place in a safe location without putting tension on sensor wires.



6. Inspect the shuttle and clean any sediment or debris that has built up. Replace O-ring if necessary.



3. Remove the aluminum guarding and cover screws from cover assembly.



7. Inspect and clean all surfaces of the cover. Replace cover O-rings if necessary.



4. Remove complete cover assembly. Do not remove motor assembly at this time.



- 7A. If a new Teflon® gasket is required, remove the locking disk (special tool required) and then the damaged gasket. Press the replacement disk into the groove evenly.
NOTE: For best results, remove motor assembly from cover by unthreading the 4 bolts on top of the assembly.

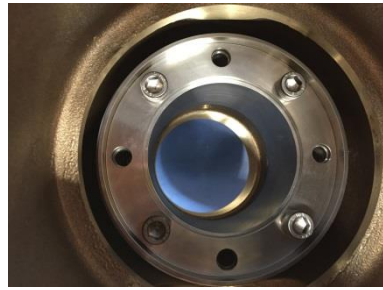

8. Reassemble the cover assembly. Place in a safe location.

Remove Sleeve Assembly from Body



Disassemble Sleeve

9. Remove sleeve assembly from valve body and clean all surfaces. Replace O-ring on bottom of part if damaged or worn. If necessary, disassemble the sleeve to install replacement Teflon® disk.

- 9B. **Model NV-300-LF:** Using 5/32" Allen key, remove the 4 bolts at the bottom of the sleeve assembly. Remove the sleeve assembly from valve body. Next, fully disassemble the sleeve by removing 4 bolts using a 5/16" Allen Key.



Loosen Sleeve Locking Nut
(Use fork side of tool on the upper notches)



10. Reassemble the sleeve assembly and carefully install it back into valve body.

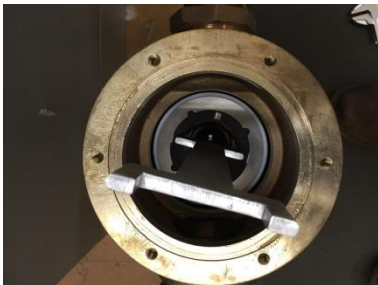

Remove Sleeve Assembly
Use flat side of tool on the lower notches



- 9A. **Models NV-150-LF and NV-200-LF:** First loosen the locking nut and then remove the sleeve assembly by unthreading it from the base (special tool required).

11. Reinstall the cover assembly and guarding.
12. Reinstall bracket and Nucleus control box
13. Reconnect Motor Connectors and power up the Nucleus control box

NV-150-LF	MINIMUM	PRESSURE DROP										
	FLOW (GPM) (l/min)	5	10	15	20	25	30	35	40	45	50	PSI
		0.3	0.70	0.97	1.4	1.7	2.1	2.4	2.8	3.1	3.4	BAR
	0.25*	50	72	86	100	115	122	136	140	158	165	GPM
	0.95*	189	273	326	379	435	462	515	530	598	625	l/min

NV-200-LF	MINIMUM	PRESSURE DROP										
	FLOW (GPM) (l/min)	5	10	15	20	25	30	35	40	45	50	PSI
		0.3	0.7	0.97	1.4	1.7	2.1	2.4	2.8	3.1	3.4	BAR
	0.25*	80	115	130	147	165	173	189	198	215	226	GPM
	0.95*	303	435	492	556	625	655	715	750	814	856	l/min

NV-300-LF	MINIMUM	PRESSURE DROP										
	FLOW (GPM) (l/min)	5	10	15	20	25	30	35	40	45	50	PSI
		0.3	0.7	0.97	1.4	1.7	2.1	2.4	2.8	3.1	3.4	BAR
	0.25*	97	135	163	191	213	235	262	288	296	303	GPM
	0.95*	366	510	616	722	805	888	990	1089	1119	1145	l/min

NV-150-LF-2PS	MINIMUM	PRESSURE DROP										
	FLOW (GPM) (l/min)	5	10	15	20	25	30	35	40	45	50	PSI
		0.3	0.7	0.97	1.4	1.7	2.1	2.4	2.8	3.1	3.4	BAR
	0.25*	100	144	177	200	222	244	262	280	305	330	GPM
	0.95*	378	544	669	756	839	922	990	1058	1153	1247	l/min

NV-200-LF-2PS	MINIMUM	PRESSURE DROP										
	FLOW (GPM) (l/min)	5	10	15	20	25	30	35	40	45	50	PSI
		0.3	0.7	0.97	1.4	1.7	2.1	2.4	2.8	3.1	3.4	BAR
	0.25*	160	230	262	294	320	346	371	396	424	452	GPM
	0.95*	605	896	990	1111	1210	1308	1402	1497	1603	1709	l/min

NV-300-LF-2PS	MINIMUM	PRESSURE DROP										
	FLOW (GPM) (l/min)	5	10	15	20	25	30	35	40	45	50	PSI
		0.3	0.7	0.97	1.4	1.7	2.1	2.4	2.8	3.1	3.4	BAR
	0.25*	194	270	326	382	432	470	523	576	596	606	GPM
	0.95*	733	1021	1232	1444	1633	1777	1977	2177	2253	2291	l/min

NV-300-LF-3PS	MINIMUM	PRESSURE DROP										
	FLOW (GPM) (l/min)	5	10	15	20	25	30	35	40	45	50	PSI
		0.3	0.7	0.97	1.4	1.7	2.1	2.4	2.8	3.1	3.4	BAR
	0.25*	291	405	489	573	639	705	785	864	887	909	GPM
	0.95*	1100	1531	1848	2166	2415	2665	2967	3266	3353	3436	l/min

OPTIONAL OUTLET SETUP PIPING (BY OTHERS)

The addition of this piping arrangement (extra tee and ball valve) eliminates the need to turn showers on and off throughout the building at setup. The flows required in the setup instructions are set by using Ball Valve A. (make sure main outlet ball valve is closed).

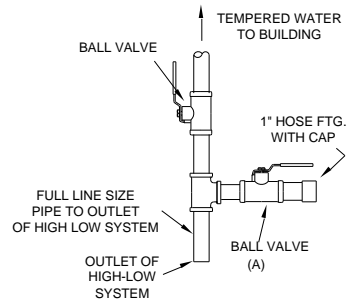

CAUTION! ALL THERMOSTATIC WATER MIXING VALVES AND SYSTEMS HAVE LIMITATIONS! THEY WILL NOT PROVIDE THE DESIRED PERFORMANCE OUTSIDE OF THEIR FLOW CAPACITY RANGE! CONSULT THE CAPACITY CHART BELOW AND OBSERVE MINIMUM FLOWS SHOWN.

LIMITED WARRANTY

Leonard Valve Company (hereinafter, "Leonard") warrants the original purchaser that products manufactured by Leonard will be free from defects in material or workmanship under normal conditions of use, when properly installed and maintained in accordance with Leonard's instructions, for a period of one year from the date of shipment. During this period, Leonard will at its option repair or replace any product, or part thereof, which shall be returned, freight prepaid, to the Leonard factory and determined by Leonard to be defective in materials or workmanship. Leonard provides no warranty, express or implied, which extends beyond the description contained herein. LEONARD SPECIFICALLY DISCLAIMS ANY AND ALL IMPLIED WARRANTIES OF MERCHANTABILITY OR OF FITNESS FOR A PARTICULAR PURPOSE. Nonetheless, some jurisdictions may not allow the disclaimer of certain implied warranties, in which case Leonard hereby limits such implied warranties to the duration of the limited warranty period contained herein. Some jurisdictions may not allow limitations on how long an implied warranty lasts, so the foregoing durational limitation may not apply to you. In no event will Leonard be liable for labor or incidental or consequential damages. Any alteration or improper installation or use of this product will void this limited warranty. If any provision of this limited warranty is prohibited by law in the applicable jurisdiction, such provision shall be null and void, but the remainder of this limited warranty shall continue in full force and effect.

COMMISSIONED PARAMETERS RECORD KEEPER

Use the table below to record all of the commissioned parameters from the Nucleus. These parameters can be referenced later using this form.

PARAMETER	VALUE
5V Motor	
Scale	
Min Temp	
Max Temp	
Err TTML	
Err TTL	
Aux2 Flow	
Temp 5 min	
Temp 5 max	
Temp 6 min	
Temp 6 max	
Temp 7 min	
Temp 7 max	
Temp 8 min	
Temp 8 max	