

INSTALLATION SETUP AND OPERATING INSTRUCTIONS EMERGENCY MIXING VALVE SYSTEM 211

IMPORTANT! Provide valve serial number (located on valve body) when ordering parts!!
Compliance.....ANSI Z 358-1



WARNING: This product can expose you to chemicals including lead, which is known to the State of California to cause cancer. For more information, go to www.P65Warnings.Ca.gov

211-TB

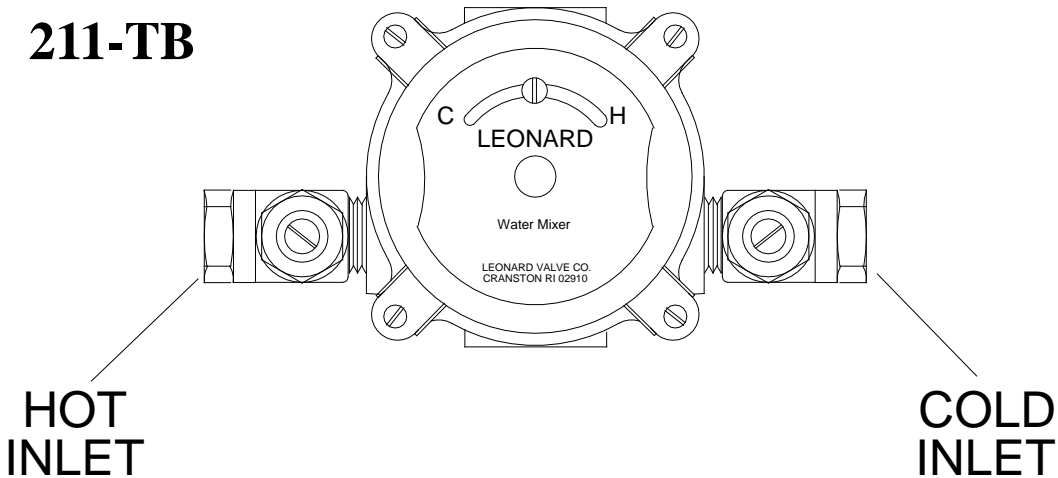

INSTALLATION

| | |
|--|--|
| <ol style="list-style-type: none"> 1. Valve should be installed at a location where it can easily be cleaned, adjusted or repaired. 2. The inlets are clearly marked on the valve body casting. Connect the hot water into the inlet marked "HOT" and cold water into the inlet marked "COLD." | <ol style="list-style-type: none"> 3. The checkstops furnished must be installed on both supply lines as shown above. 4. Use solder or pipe cement sparingly. Supply pipes should be flushed before the valve is connected. Flush outlet pipe and valve as soon as it is connected. Maximum Operating Pressure 125PSI (860 KPA) for Hot and Cold Water. |
|--|--|

NOTE: It may be necessary to recirculate the tempered water to the face/eyewash should the piping be exposed to excessive hot or cold conditions. Consult factory for proper piping.

CAUTION

IMPORTANT! These systems are designed to provide mixed water from 60 to 90°F (15 to 32°C) for eye/face wash applications only. Call Leonard for systems designed to operate at temperatures outside of this range.

REMEMBER! THIS IS A CONTROL SYSTEM WHICH MUST BE CLEANED AND MAINTAINED ON A REGULAR BASIS (SEE MAINTENANCE GUIDE AND RECORD MGR-1001).

1360 Elmwood Avenue, Cranston, RI 02910 USA
Phone: 401.461.1200 Fax: 401.941.5310
Email: info@leonardvalve.com
Web Site: <http://www.leonardvalve.com>

ADJUSTMENT AND SERVICE

Leonard Type 211 Thermostatic Water Mixing Valves are simple in design and may be easily cleaned, adjusted and repaired. If the installation is accessible, servicing may be completed without disconnecting the valve.

NOTE: Thermostatic Water Mixing Valves are **REGULATING** mechanisms, which must be regularly maintained to provide best performance. Frequency of cleaning depends on quality of local water conditions and usage. (See Maintenance Guide and Record MGR-1000 and ANSI Z358.1).

TO RESET ADJUSTABLE HIGH TEMPERATURE LIMIT STOP:

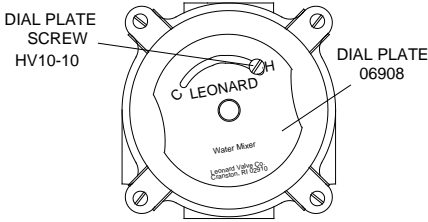
| | |
|--|---|
|  <ol style="list-style-type: none"> 1. While valve is running, remove dial plate screw HV10-10 and turn dial plate to maximum setting 90°F (32.2°C) 2. Remove Dial Plate 06908 and reinstall so screw hole is located at the end of the slot (at 'H' on the dial plate) 3. Reattach and tighten dial plate screw | <p style="text-align: center;">WARNING</p> <p>WARNING! This Thermostatic Mixing Valve has an adjustable high temperature limit stop which must be checked. If temperature is too high, the installer MUST RESET this stop immediately. Always check the temperature of the mixed water when the lever handle is turned to full HOT. Excessively hot water is DANGEROUS AND MAY CAUSE SCALDING!</p> <p>The high temperature limit stop is factory set at approximately 90°F (32°C) with an incoming hot water supply temperature of 135°F (57°C). If the incoming hot water on the job is higher than 135°F, the valve when turned to full hot will deliver water in excess of 90°F (32°C) and the high temperature limit stop MUST BE RESET BY THE INSTALLER.</p> |
|--|---|

TROUBLESHOOTING INSTRUCTIONS

| | | |
|--|---|---|
| <p style="text-align: center;">PACKINGS & GASKETS</p> | <p>Leak at pointer rod. Leak between valve cover and base.</p> | <p>PARTS REQUIRED: 06806 Cover Gasket MU-5A O'Ring</p> |
| <p style="text-align: center;">PORT SLEEVE ASSEMBLY</p> | <p>Valve outlet temperature cannot be adjusted or will not mix consistently. .</p> | <p>TAG-1M Port Sleeve Assembly Or KIT# R/211NM Rebuild REBUILDING KIT</p> |
| <p style="text-align: center;">THERMOSTAT GROUP</p> | <p>After cleaning or replacing port sleeve assembly, valve will not hold temperature.</p> | <p>06920 Thermostat Group Or KIT#R/211NM REBUILDING KIT</p> |
| <p style="text-align: center;">CHECKSTOPS</p> | <p>Hot water bypass in cold line. Supplies cannot be shut off completely. Leak at checkstop bonnet.</p> | <p>KIT#B</p> |

SEE PAGE 5 FOR COMPLETE PARTS BREAKDOWN AND PARTS KITS

If installed on a circulated hot water system, make certain the valve is piped according to Leonard Required Methods of Piping (see page 3).

REMEMBER! THIS IS A CONTROL DEVICE WHICH MUST BE CLEANED AND MAINTAINED ON A REGULAR BASIS. (SEE MAINTENANCE GUIDE AND RECORD, MGR-1001).

REQUIRED METHOD OF PIPING TA VALVE

METHOD #1

Required when hot water is to be circulated to a thermostatic mixing valve which is a substantial distance from the hot water source.

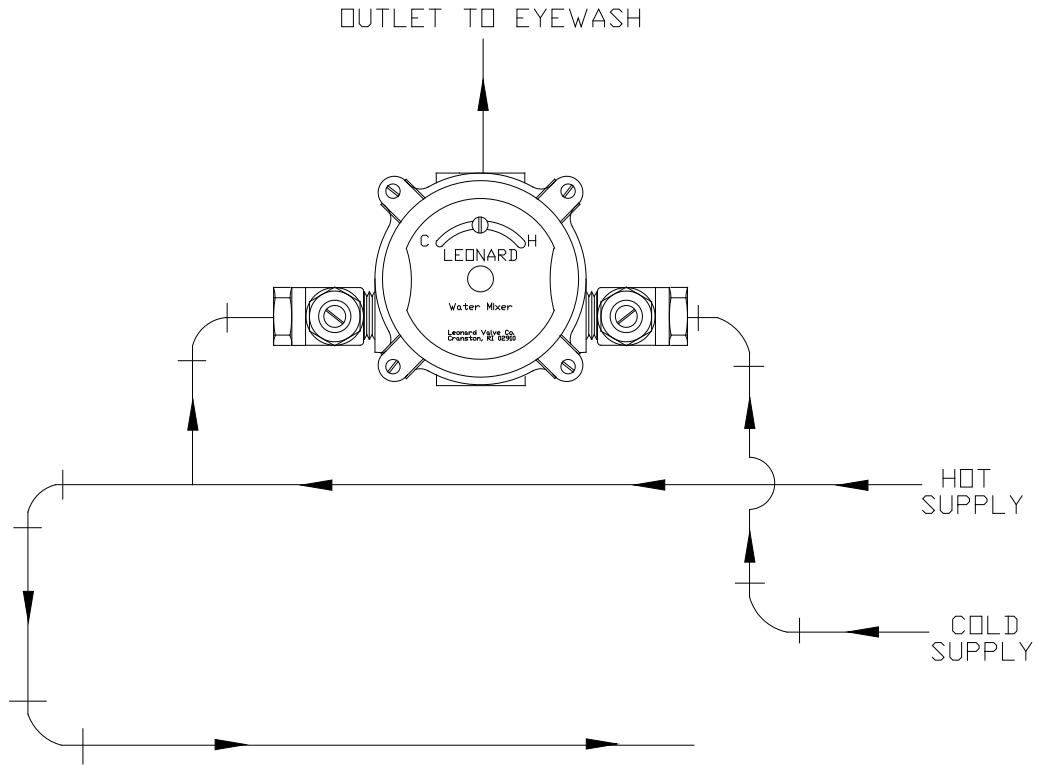

211

REMEMBER! THIS IS A CONTROL DEVICE WHICH MUST BE CLEANED AND MAINTAINED ON A REGULAR BASIS. (SEE MAINTENANCE GUIDE AND RECORD, MGR-1001).

This unit must be cycled each time the emergency equipment is checked. See ANSI Z358.1, Maintenance and Training section:

INSTRUCTIONS FOR DISMANTLING VALVE

Turn off hot and cold supplies to this valve. Remove four cover screws MU-2C, lift off cover and thermostat group 06920 (DWG 1). After installing new parts, it will be necessary to reset Dial Plate to obtain correct temperature range from Cold to Hot. See page 2 instructions "TO RESET ADJUSTABLE HIGH TEMPERATURE LIMIT STOP."

TO CLEAN PORT SLEEVE ASSEMBLY

To clean port sleeve assembly TAG-1M (DWG 2.): Remove base stud TA-5. Back off port sleeve nut 3402 as far as it will go into base. Slide TAG-1M port sleeve assembly toward port sleeve nut and lift out of valve base. Clean part TAG-1M with a soft cloth; **DO NOT** use abrasives such as emery cloth or sandpaper. After cleaning, wash parts in clean water and reassemble in valve base. When reassembling port sleeve assembly **BE SURE TO INSTALL WITH SHORT SLOT END IN BASE AND LONG SLOT END AT PORT SLEEVE NUT**. Locate one set of port slots facing directly toward front of the valve. Tighten port sleeve nut 3402 just enough to hold port sleeve in place. Do not cramp or distort port sleeve by exerting excessive pressure when tightening port sleeve nut.

TO CLEAN THERMOSTAT GROUP

To clean thermostat group 06920 (DWG 1.), remove dial plate 06908 by loosening dial plate screw HV10-10 and pull off. Remove thermostat group by pushing rod through cover. **BE CAREFUL NOT TO PULL COILS OUT OF SHAPE**. If deposit has collected on thermostat coil, clean it off with a brush in cleaning solution and wash well before reassembly. Cleaning solution should be non-corrosive and grit free.

To reassemble: be sure, port sleeve assembly is in place and is working freely from side to side. Reinstall base stud TA-5, then place thermostat group 06920 on base stud and **BE SURE DRIVING BALL ON PORT SLEEVE ASSEMBLY TAG-1M IS INSERTED IN HOLE ON LOWER COIL BRACKET (DWG 3.)** Move thermostat back and forth to be sure all parts are free. Replace cover on valve base, install the four cover screws, and turn on hot and cold water supplies. See instructions below "To Reset High Temperature Limit Stop" to properly reset limit stop.

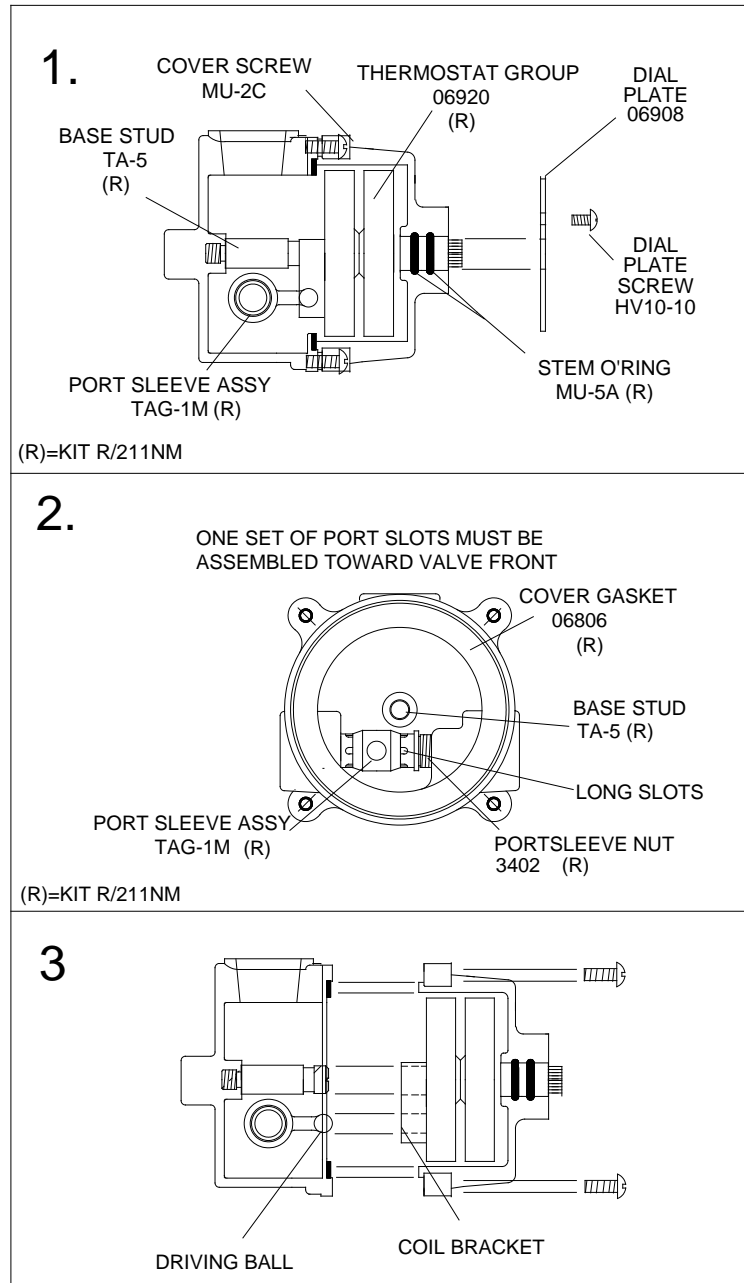

After installation, adjustment, and cleaning, always check the temperature of the valve when turned to full **HOT** per the warning on the front page, using a thermometer. Also check and if necessary adjust the temperature of the hot water source. **EXCESSIVELY HOT WATER (OVER 110°F) IS DANGEROUS AND MAY CAUSE SCALDING!!**

REMEMBER! THIS IS A CONTROL DEVICE WHICH MUST BE CLEANED AND MAINTAINED ON A REGULAR BASIS. (SEE MAINTENANCE GUIDE AND RECORD, MGR-1001).

211 VALVE PARTS

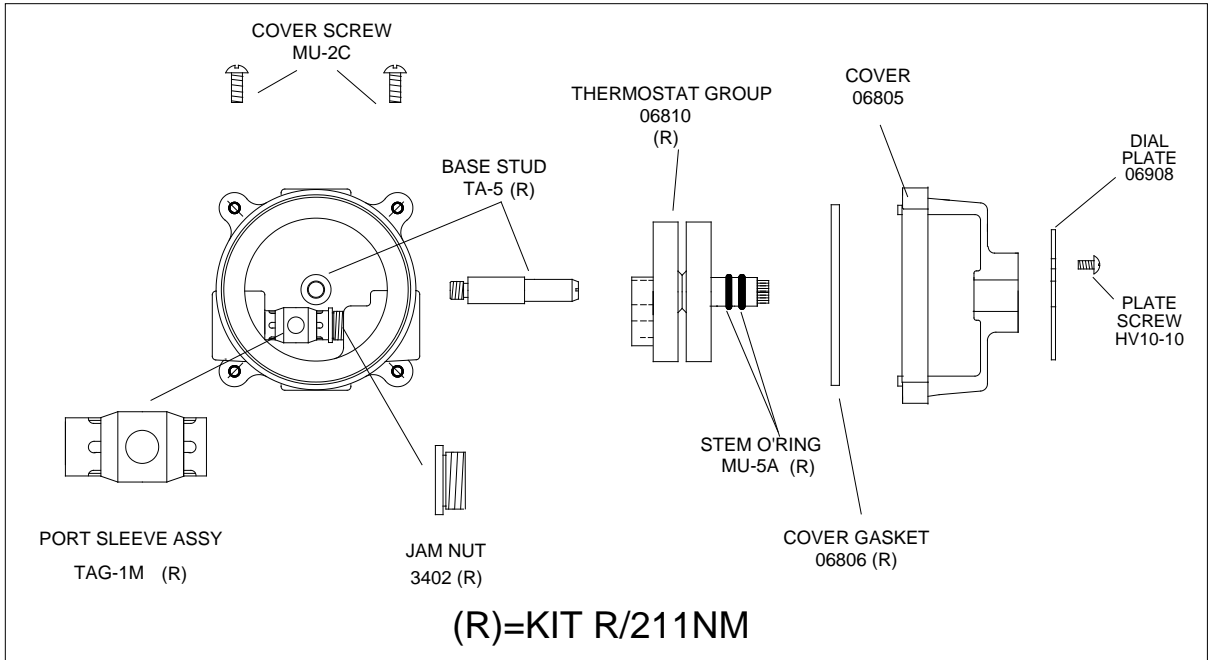

REPAIR KIT

TO CLEAN THERMOSTAT GROUP

If a deposit has collected on the thermostat group (06810), soak and brush in a non-corrosive solution

CHECKSTOP PARTS

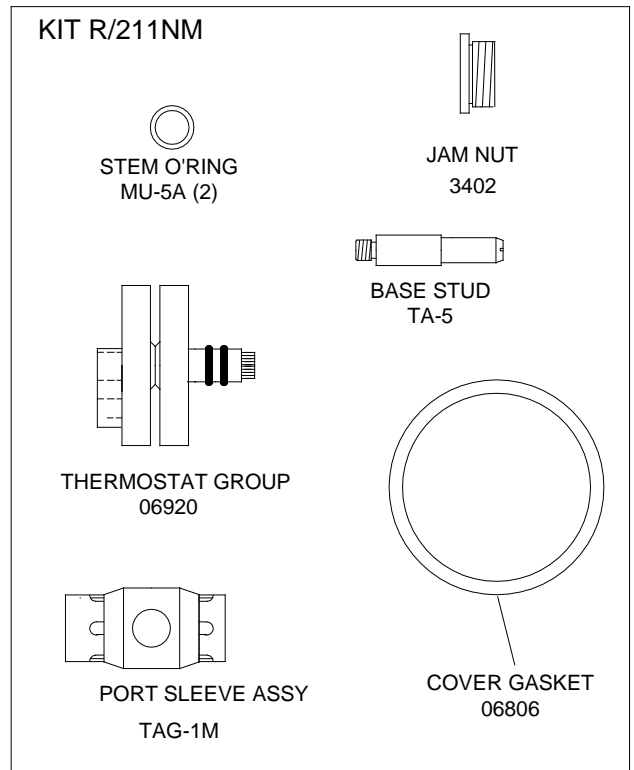
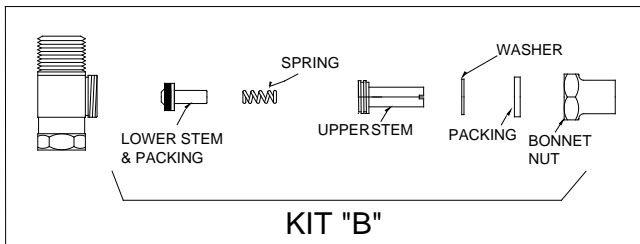

REMEMBER! THIS IS A CONTROL DEVICE WHICH MUST BE CLEANED AND MAINTAINED ON A REGULAR BASIS (SEE MAINTENANCE GUIDE AND RECORD, MGR-1001).

NOTE: AFTER INSTALLING NEW PARTS IT WILL BE NECESSARY TO RESET THE ADJUSTABLE HIGH TEMPERATURE LIMIT STOP, (SEE PAGE 2).

FLOW CAPACITIES

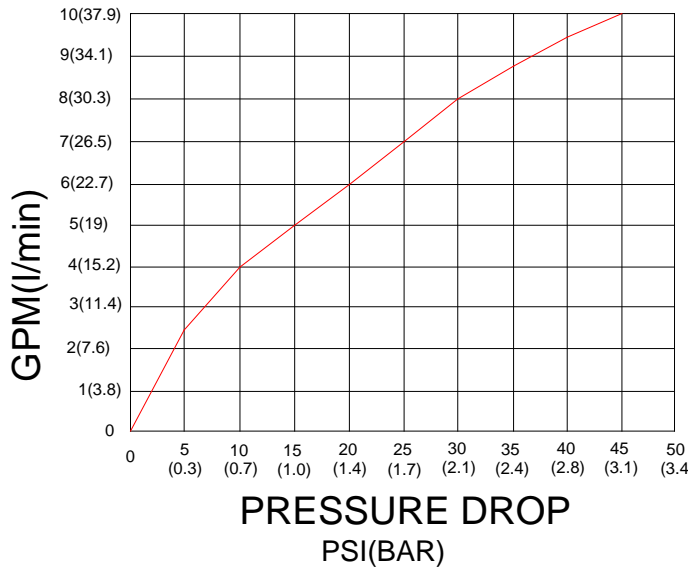

| MODEL | IN | OUT | MINIMUM FLOW (GPM) L/MIN | INTERNAL COLD WATER BY-PASS MINIMUM | PRESSURE DROP | | | | | | | | | | PSI BAR |
|-------|------|------|-----------------------------|-------------------------------------|---------------|----------|----------|-----------|-----------|-----------|-----------|-----------|-----------|-------|------------|
| | | | | | ⑤ 0.3 | ⑩ 0.7 | ⑮ 1.0 | 20 1.4 | 25 1.7 | 30 2.1 | 35 2.4 | 40 2.8 | 45 3.1 | | |
| 211 | 1/2" | 1/2" | 2.0 | 4.0 | 2.5 | 4 | 5 | 6 | 7 | 8 | 8.5 | 9.5 | 10 | GPM | |
| | | | 7.6 | 15.0 | 9.5 | 15 | 19 | 23 | 27 | 30 | 32 | 36 | 38 | L/MIN | |

CAUTION! All thermostatic water mixing valves have limitations. They will not provide the desired accuracy outside of their flow capacity range. Consult the capacity chart and **DO NOT OVERSIZE**. Minimum flow must be no less than shown below.

IMPORTANT! These systems are designed to provide mixed water from 60 to 90°F (15 to 32°C) for face/eyewash applications only. Call Leonard for systems designed to operate at temperatures outside of this range.

LIMITED WARRANTY

Leonard Valve Company (hereinafter, "Leonard") warrants the original purchaser that products manufactured by Leonard will be free from defects in material or workmanship under normal conditions of use, when properly installed and maintained in accordance with Leonard's instructions, for a period of one year from the date of shipment. During this period, Leonard will at its option repair or replace any product, or part thereof, which shall be returned, freight prepaid, to the Leonard factory and determined by Leonard to be defective in materials or workmanship. Leonard provides no warranty, express or implied, which extends beyond the description contained herein. LEONARD SPECIFICALLY DISCLAIMS ANY AND ALL IMPLIED WARRANTIES OF MERCHANTABILITY OR OF FITNESS FOR A PARTICULAR PURPOSE. Nonetheless, some jurisdictions may not allow the disclaimer of certain implied warranties, in which case Leonard hereby limits such implied warranties to the duration of the limited warranty period contained herein. Some jurisdictions may not allow limitations on how long an implied warranty lasts, so the foregoing durational limitation may not apply to you. In no event will Leonard be liable for labor or incidental or consequential damages. Any alteration or improper installation or use of this product will void this limited warranty. If any provision of this limited warranty is prohibited by law in the applicable jurisdiction, such provision shall be null and void, but the remainder of this limited warranty shall continue in full force and effect.

1360 Elmwood Avenue, Cranston RI 02910 USA

Phone 401-461-1200 Fax 401-941-5310

EMAIL: info@leonardvalve.com WEB: <http://www.leonardvalve.com>