

Thermostatic MIXING VALVES

ECO-MIX™

TM-26-____-LF

TM-26-LF ¾" inlets and outlet

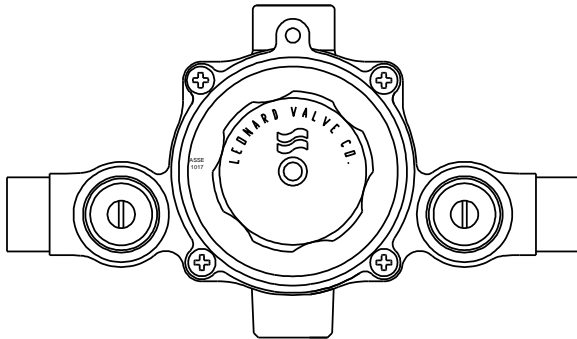

- Thermostatic water mixing valve with 1 GPM minimum flow
- Dura-trol® solid bimetal thermostat directly linked to valve porting to control the intake of hot and cold water and compensate for supply temperature or pressure fluctuations. Dura-trol® is highly responsive and cannot be damaged by extremes in temperature.
- ¾" Sweat inlets and outlet
- 1 GPM (3.7 l/m) minimum flow capacity
- Integral combination checkstops
- Internal parts of lead free bronze, lead free brass, and stainless steel
- Integral wall support
- Color-coded dial, HOT-COLD with directional indicators
- Maximum operating pressure 125 PSI (860 KPA)
- Adjustable high temperature limit stop set for 120° F (49° C) *
- See Flow Capacity Chart, reverse side, to select correct size
- Locking temperature adjustment knob
- Rough bronze finish

SWEAT CONNECTIONS ONLY

OPTIONS:

- SUFFIX BDT – Ball valve with dial thermometer (shown page 2)
- SUFFIX IT – Inlet thermometers (ship loose)
- SUFFIX TC – Test connection (ship loose)
- SUFFIX LWS – Less Wall support

NOTE: CP option is NOT available

Valve assembly is certified to meet Low-Lead requirements of wetted surface area containing less than 0.25% lead by weight. All other fittings and components, the sum total of which comprise the wetted surface of this product contains less than one quarter of one percent of lead by weight.

Note: Leonard Valve Company reserves the right of product, or design modifications without notice or obligation.

Valve is ASSE 1017 Certified



Valve is CSA Certified



WARNING: This product can expose you to chemicals including lead, which is known to the State of California to cause cancer. For more information, go to www.P65Warnings.Ca.gov

*NOTE: A limit stop, set for 120°F (49°C), is simply a mechanical setting to prevent excessive handle rotation. If incoming water is hotter than 150°F (65.5°C), the temperature of the factory test, the valve when turned to full HOT may deliver water in excess of 120°F and the limit stop MUST BE RESET BY THE INSTALLER

Engineer's Approval

Job # _____

Arch/Eng. _____

Contractor _____



1360 Elmwood Avenue, Cranston, RI 02910 USA

Phone: 401.461.1200 Fax: 401.941.5310

Email: info@leonardvalve.com

Web Site: <http://www.leonardvalve.com>

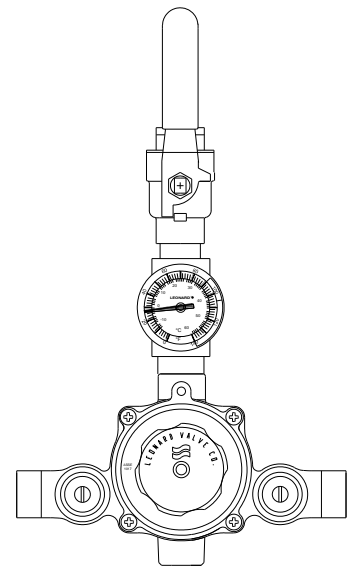
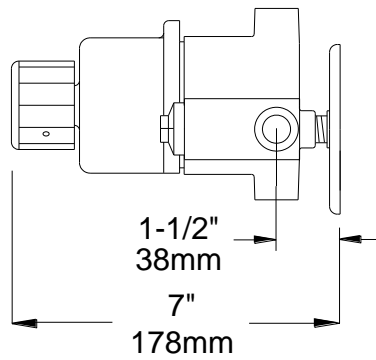
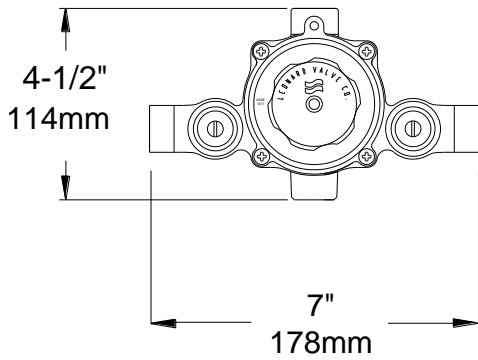

BDT OPTION

**REQUIRED PIPING
METHOD #1**

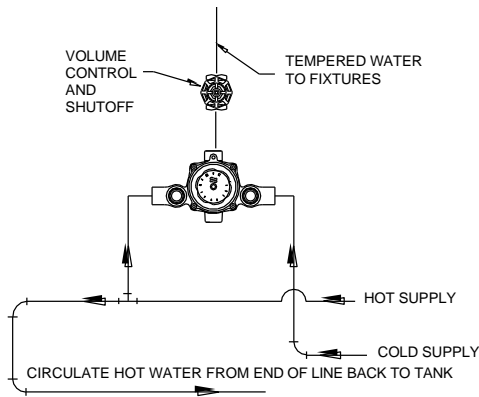

**REQUIRED PIPING
METHOD #2**

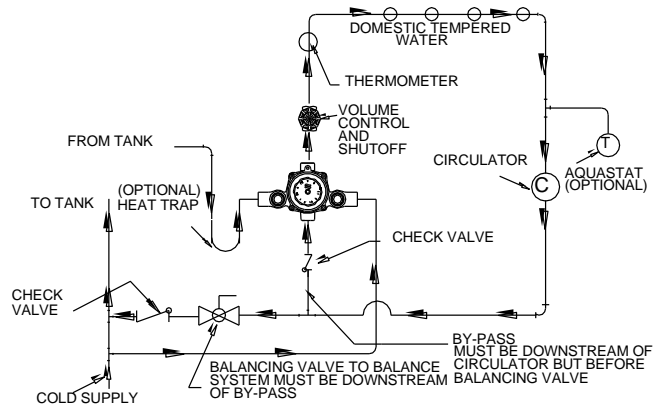

MODEL	IN	OUT	MINIMUM FLOW (GPM) (l/min)	SYSTEM PRESSURE DROP (PSIG)										
				5	10	15	20	25	30	35	40	45	50	PSI
				.3	.7	.97	1.4	1.7	2.1	2.4	2.8	3.1	3.4	BAR
TM-26-LF	3/4"	3/4"	1.0 3.7	7 26	10 38	13 49	15 57	17 64	19 72	21 80	23 87	25 95	26 98	GPM l/min

CAUTION! All thermostatic water mixing valves have limitations. They will NOT provide the desired accuracy outside of their flow capacity range. Consult the Flow Capacity Chart and DO NOT OVERSIZE. Minimum flow must be no less than as indicated.



1360 Elmwood Avenue, Cranston, RI 02910 USA

Phone: 401.461.1200 Fax: 401.941.5310

Email: info@leonardvalve.com

Web Site: <http://www.leonardvalve.com>