

## INSTALLATION ADJUSTMENT SERVICE HIGH-LOW MANIFOLD

**TM-2020A**   
**ASSE 1017 LISTED**

**IMPORTANT! Provide serial numbers for both valves when ordering parts!!**

### INSTALLATION

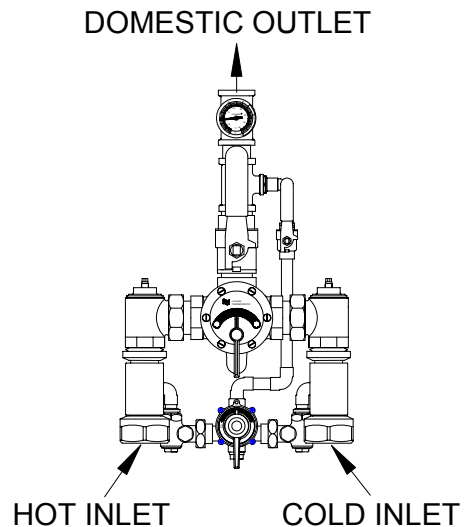
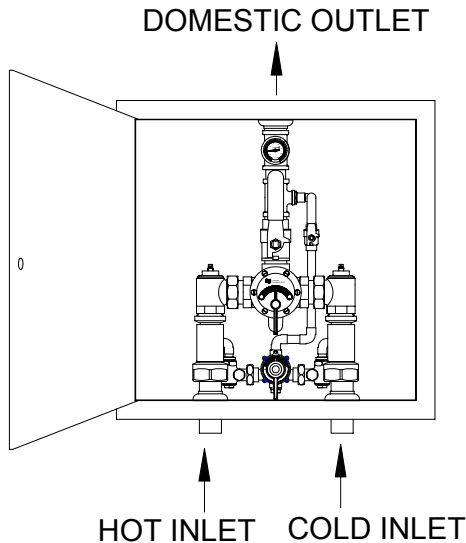

1. Type TM manifold systems are factory pre- assembled and tested and include large and small thermostatic water mixing valves which function as a system to meet both high and low demand for tempered water.
2. System should be installed at a location where it can easily be cleaned, adjusted or repaired.
3. System supplies must be connected as shown (Hot-left, Cold-right). Exercise caution when soldering.

4. Flush pipes thoroughly after system has been connected.
5. If this assembly is installed on a recirculated hot water system it **MUST** be piped according to **LEONARD'S REQUIRED PIPING METHODS** (see pages 4 & 5).
6. Refer to page 3 of this bulletin for correct Setup Instructions.

**Maximum Operating Pressure 125PSI (860 KPA) for Hot and Cold Water.**

#### CAUTION

All thermostatic water-mixing valves have limitations. They will not provide the desired accuracy outside of their flow capacity range. Consult the capacity chart on page 8. Minimum flow must be no less than as shown.

## ADJUSTMENT AND SERVICE

Leonard Type TM Thermostatic Water Mixing Valves are simple in design and may be easily cleaned, adjusted and repaired. If the installation is accessible, servicing may be completed without disconnecting the valves.

**NOTE:** High Low Manifold Systems include Thermostatic Water Mixing Valves, which must be regularly maintained to provide best performance. Frequency of cleaning depends on quality of local water conditions and usage. See Maintenance Guide and Record MGR-1001



### WARNING



These mixing valves are equipped with an adjustable high temperature limit stop factory set at approximately 120°F (49°C) with an incoming hot water supply temperature of 150°F (65.5°C). If the hot water supply temperature of the job is greater than 150°F (65.5°C), the valves when turned to full HOT will deliver water in excess of 120°F (49°C) and the limit stop **MUST BE RESET BY THE INSTALLER!**

### TO RESET ADJUSTABLE HIGH TEMPERATURE LIMIT STOP:

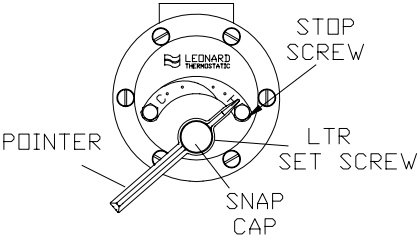
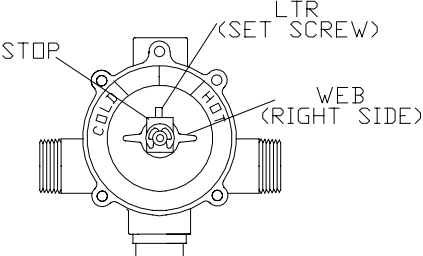
LARGE MIXING VALVE	SMALL MIXING VALVE
	
<ol style="list-style-type: none"><li>1. Loosen LTR screw</li><li>2. Remove SNAP CAP, SCREW &amp; WASHER, Remove POINTER.</li><li>3. Temporarily place POINTER on the spline rod, turn RIGHT for warmer temperature, turn LEFT for cooler temperature. When valve is delivering warmest temperature desired, remove the pointer.</li><li>4. Replace POINTER on the spline rod so that its RIGHT edge is resting against the WEB located on the RIGHT SIDE OF THE COVER.</li><li>5. The new maximum temperature has now been set. Test this temperature by holding a thermometer under the flow of water to be certain it is as desired.</li></ol>	<ol style="list-style-type: none"><li>1. Remove POINTER, RETAINING RING and STOP</li><li>2. Loosen LTR screw</li><li>3. Temporarily place POINTER on the spline rod, turn LEFT for cooler temperature, turn RIGHT for warmer temperature. When valve is delivering warmest temperature desired, remove the pointer</li><li>4. Push stop on rod so that its RIGHT edge is resting against the top side of the web which is cast on the RIGHT SIDE OF THE COVER.</li><li>5. Replace stop retaining ring.</li><li>6. Replace POINTER so that it is pointing to the extreme HOT position. The new maximum temperature has now been set. Test the temperature by holding a thermometer under the flow of water to be certain it is as desired.</li></ol>

### IMPORTANT! BOTH MIXING VALVES MUST BE SET AT THE SAME OPERATING TEMPERATURE.

#### SEE PAGES: 6 & 7 FOR COMPLETE PARTS BREAKDOWN

Check for significant variations in outlet flow. Thermostatic valves will NOT provide the desired accuracy outside of their flow capacity range. Minimum flows must be no less than shown (see Flow Capacities, page 8).

If installed on a recirculated hot water system, make certain the valve is piped according to Leonard's Required Piping Methods (see page 4).

**REMEMBER! THIS IS A CONTROL DEVICE WHICH MUST BE CLEANED AND MAINTAINED ON A REGULAR BASIS. (SEE MAINTENANCE GUIDE AND RECORD, MGR-1001).**

# SETUP INSTRUCTIONS

## THERMOMETER

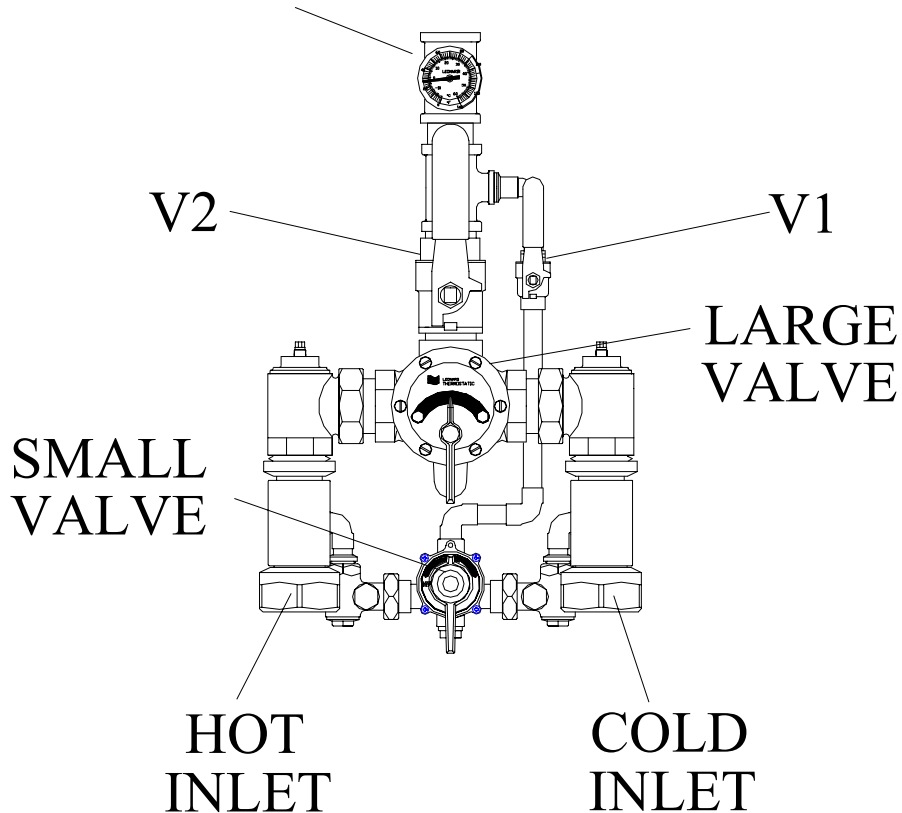

1. The High-Low Unit **MUST** be piped according to a Leonard Required Piping Method (see page 4 & 5).
2. Make sure full hot and cold supplies to this assembly are operating. The temperature of the hot water source must be properly set and maintained.
3. The circulator (if used) must be turned **OFF** before setup.
4. Turn on enough fixtures for a flow of at least 30 GPM (114 l/min.) downstream from this system. Make sure each fixture is set to deliver full "HOT" water.
5. Close outlet Valve V1 at the smaller Type TM Valve
6. Make sure Valve V2 at the large Type TM Valve is in the full open position.

6. Set outlet temperature of the large Type TM Valve to the required level.
7. Open outlet Valve V1 at the small TM Valve.
8. Shut outlet Valve V2 at the large TM valve.
9. Turn on enough fixtures for a flow of at least 2 GPM (7.6 l/min) downstream from this system. Make sure each fixture is set to deliver full "HOT" water.
10. Set outlet temperature of the small TM valve to the same temperature as the large TM Valve.
11. Open outlet Valve V2. System is operational. To balance circulation system temperature, see page 4 & 5.

•NOTE! FOR OPTIONAL OUTLET SETUP PIPING ARRANGEMENT, SEE PAGE 8

**REQUIRED PIPING METHOD #2**  
**FOR SYSTEMS CIRCULATING 8 GPM OR LESS\***  
(SEE PAGE 5, PIPING METHODS 4 AND 5 FOR HIGHER FLOW SYSTEMS)

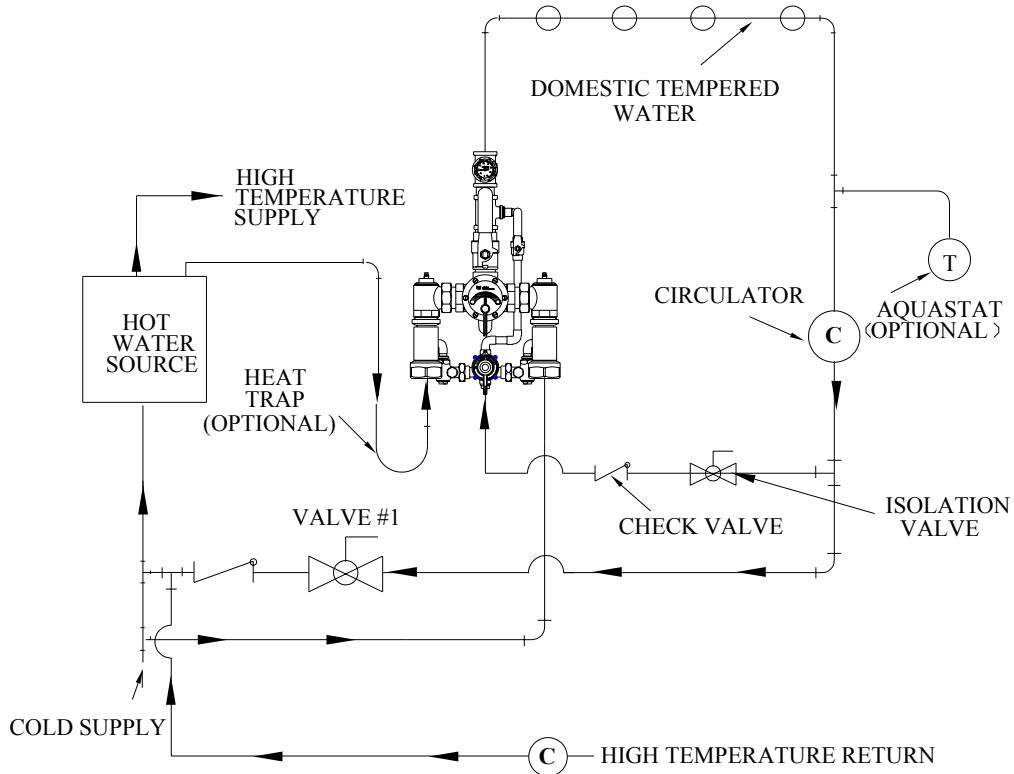

**PROCEDURE TO BALANCE CIRCULATION SYSTEM**

1. MAKE SURE NO WATER IS BEING DRAWN IN THE BUILDING. OPEN VALVE #1 APPROXIMATELY HALF WAY AND START CIRCULATOR.
2. OBSERVE TEMPERATURE UNTIL IT STABILIZES.
3. CLOSE VALVE #1 SLIGHTLY IF TEMPERATURE IS TOO HOT, OR OPEN IT SLIGHTLY IF TEMPERATURE IS TOO COLD. ALLOW TEMPERATURE TO STABILIZE, REPEAT UNTIL DESIRED CIRCULATION TEMPERATURE IS SET.

**REMEMBER! THIS IS A CONTROL DEVICE WHICH MUST BE CLEANED AND MAINTAINED ON A REGULAR BASIS (SEE MAINTENANCE GUIDE AND RECORD, MGR-1001).**

## METHOD #4

### CIRCULATED FLOWS BETWEEN 8-25 GPM

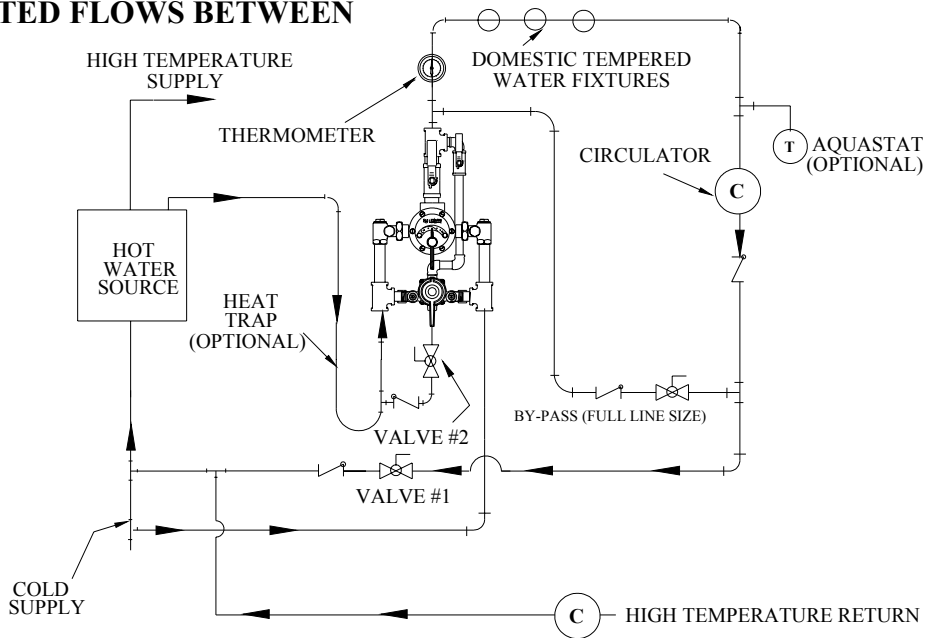

#### PROCEDURE TO BALANCE SYSTEM:

1. MAKE SURE NO WATER IS BEING DRAWN. OPEN VALVE #1 AND VALVE #2 APPROXIMATELY  $\frac{1}{2}$  WAY AND START CIRCULATOR.
2. OBSERVE TEMPERATURE UNTIL IT STABILIZES.
3. CLOSE VALVE #1 SLIGHTLY IF TEMPERATURE IS TOO HOT, OR OPEN IT SLIGHTLY IF TEMPERATURE IS TOO COLD AND ALLOW TEMPERATURE TO STABILIZE. REPEAT UNTIL DESIRED TEMPERATURE IS SET.
4. IF UNABLE TO REACH DESIRED TEMPERATURE OPEN VALVE #2 FULL, REPEAT STEPS 2 AND 3.

## METHOD #5

### CIRCULATED FLOWS GREATER THAN 25 GPM

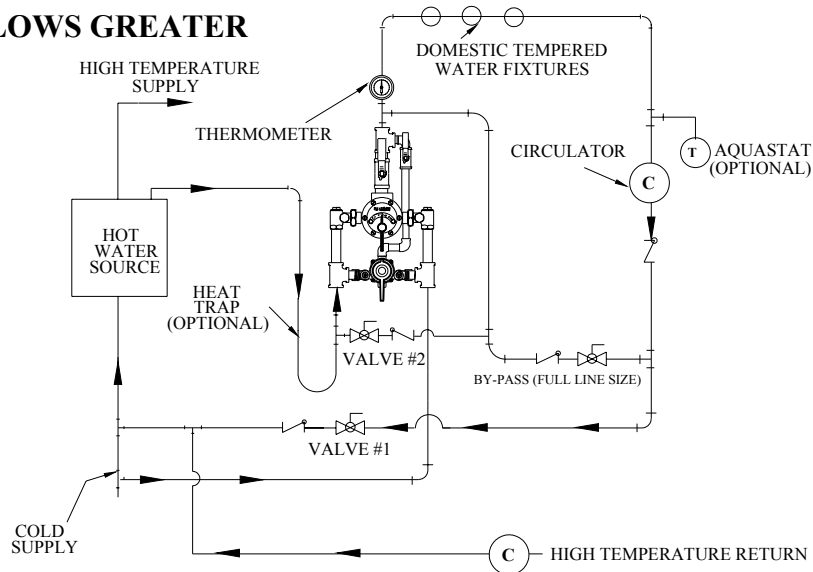

#### PROCEDURE TO BALANCE SYSTEM:

1. MAKE SURE NO WATER IS BEING DRAWN. OPEN VALVE #1 AND VALVE #2 APPROXIMATELY  $\frac{1}{2}$  WAY AND START CIRCULATOR.
2. OBSERVE TEMPERATURE UNTIL IT STABILIZES.
3. CLOSE VALVE #1 SLIGHTLY IF TEMPERATURE IS TOO HOT, OR OPEN IT SLIGHTLY IF TEMPERATURE IS TOO COLD AND ALLOW TEMPERATURE TO STABILIZE. REPEAT UNTIL DESIRED TEMPERATURE IS SET.
4. IF UNABLE TO REACH DESIRED TEMPERATURE OPEN VALVE #2 FULL, REPEAT STEPS 2 AND 3.

## INSTRUCTIONS FOR SERVICING LARGER TM VALVE

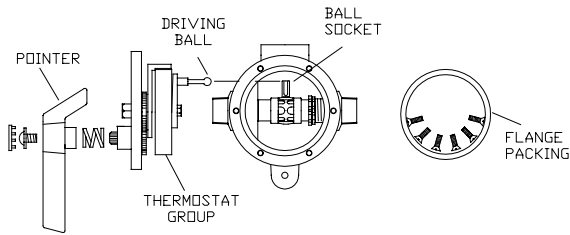

1. Loosen LTR set screw
2. Remove snap cap, screw and washer, friction spring and pointer.
3. Turn off hot and cold supplies at screwdriver checkstops. Remove TM16 cover screws to release cover and thermostatic control assembly.
4. To clean port sleeve assembly, (the thimble must move freely on the port sleeve): unscrew the check nut as far as it will go, then screw the port sleeve nut into the base. The port sleeve and thimble may be lifted out. SEE DWG "A".
5. Clean in a non-corrosive cleaning solution. **DO NOT USE ABRASIVES!** The port sleeve should be reassembled in the valve.

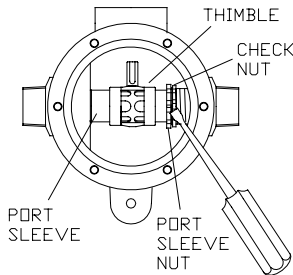

6. To clean thermostat group, remove coil sleeve stud and take off thermostat group.
7. Clean in a non-corrosive cleaning solution.
8. When reassembling, make sure driving ball of thermostat group engages the ball socket of the port sleeve assembly.

## INSTRUCTIONS FOR SERVICING SMALLER TM VALVE

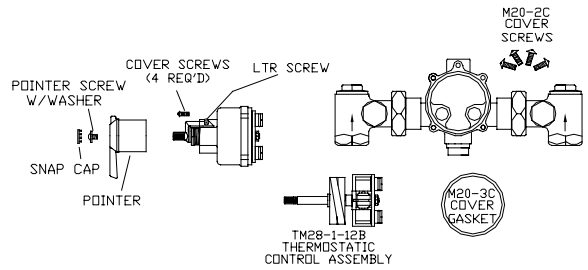

1. Loosen LTR set screw
2. Remove screw, snap cap, and handle.
3. Turn off hot and cold supplies at screwdriver checkstops. Remove M20-2C cover screws to release cover and thermostatic control assembly.
4. To remove bridge assembly, TM-28-1-8B, remove pointer rod nut (M20-10B) and pull bridge assembly off control rod.
5. To clean submerge bridge assembly in clean water or non-corrosive cleaning solution. **DO NOT USE ABRASIVES!** Be certain thimble moves freely on port sleeve. Note! Driving stud (M20-14B) must engage slot in thimble when assembling

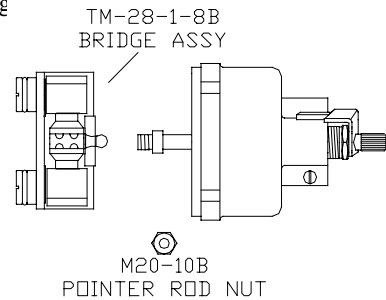

6. To disassemble bridge assembly, see drawing next page (remove M20-5B holder nuts with screwdriver in slots provided).
7. Remove thermostat group from bridge assembly, and soak in a non-corrosive cleaning solution.

### TROUBLESHOOTING INSTRUCTIONS

**Note: Provide serial number when ordering parts for either valve!**

		LARGE VALVE	SMALL VALVE
PACKING & GASKETS	<ol style="list-style-type: none"> <li>1. Leaks at stem.</li> <li>2. Leak between valve cover and base.</li> </ol>	Kit # 1/200Y	Kit # 1/28Y (Packings & Gaskets)
PORT SLEEVE/BRIDGE ASSEMBLY	<ol style="list-style-type: none"> <li>3. Valve delivers either all hot or all cold water, or will not mix consistently.</li> </ol>	Kit # R/200N	Kit #R/28 (Rebuilding Kit) or TM28-1-8B Bridge Assembly
THERMOSTAT GROUP	<ol style="list-style-type: none"> <li>4. After cleaning or replacing port sleeve/ bridge assembly, valve performance is not consistent.</li> </ol>	Kit # R/200N	Kit #R/28 (Rebuilding Kit) or TM-28-G2 Thermostat Group
CHECKSTOPS	<ol style="list-style-type: none"> <li>5. Hot water by-pass into cold line(or cold into hot).</li> <li>6. Supplies cannot be shut off completely. Supplies leak at checkstop bonnets.</li> </ol>	Kit #2/200Y	Kit #2/28Y (Checkstop Kit)

# LARGE TM VALVE PARTS

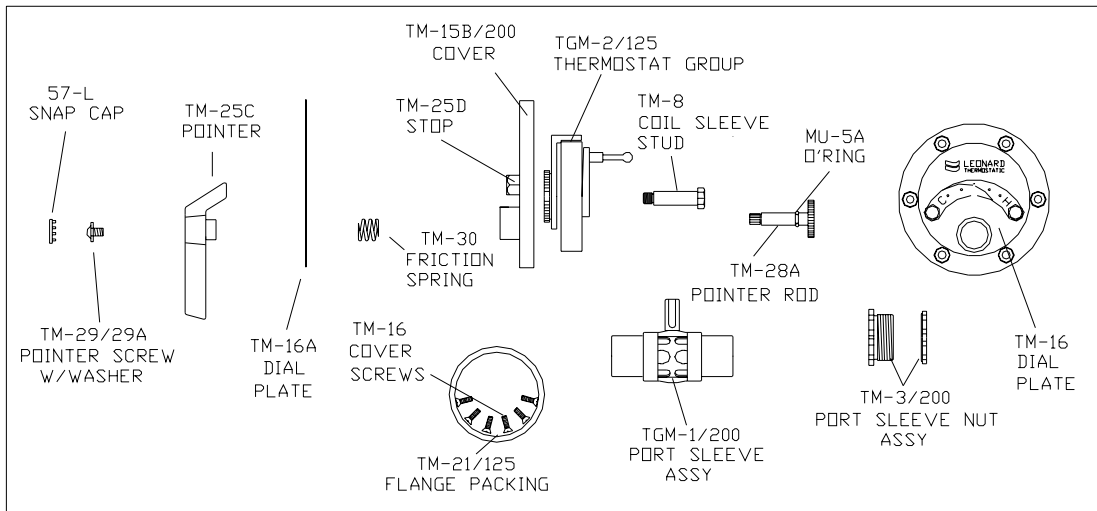

## CHECKSTOP PARTS

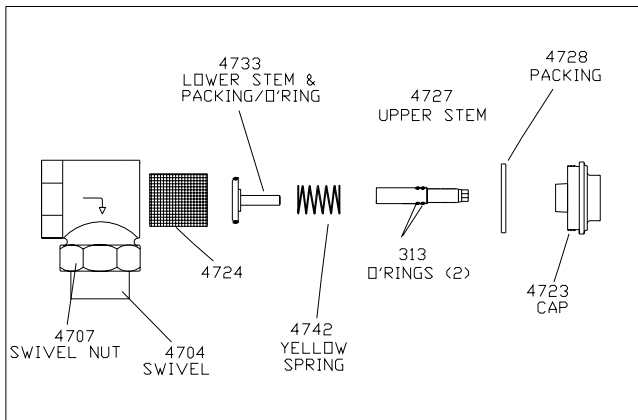

## REPAIR KITS

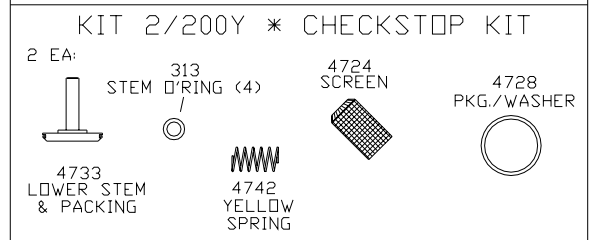
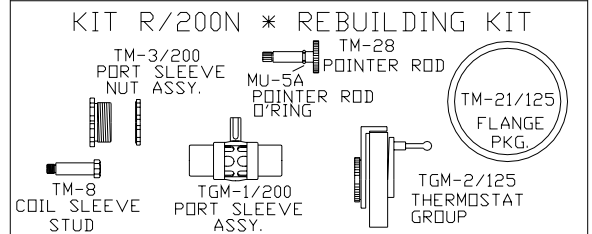
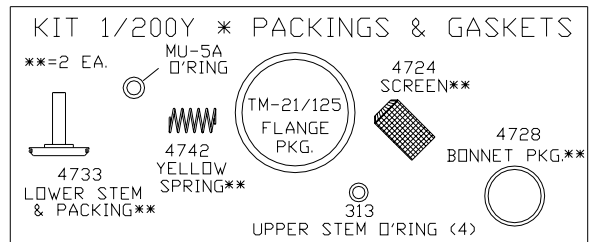

## LOCK-TYPE POINTER

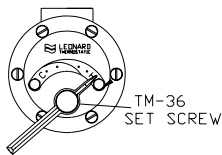

**REMEMBER!** THIS IS A CONTROL DEVICE WHICH MUST BE CLEANED AND MAINTAINED ON A REGULAR BASIS (SEE MAINTENANCE GUIDE AND RECORD)

**NOTE:** AFTER INSTALLING NEW PARTS IT WILL BE NECESSARY TO RESET THE ADJUSTABLE HIGH TEMPERATURE LIMIT STOP ON EACH VALVE (SEE PAGE 2).

# SMALL TM VALVE PARTS

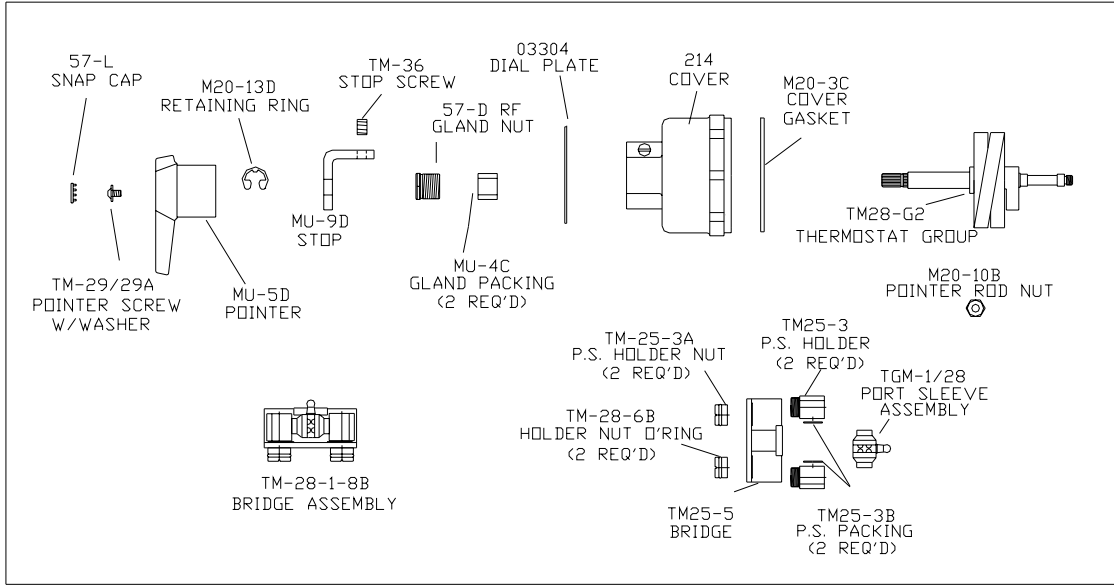

## CHECKSTOP PARTS

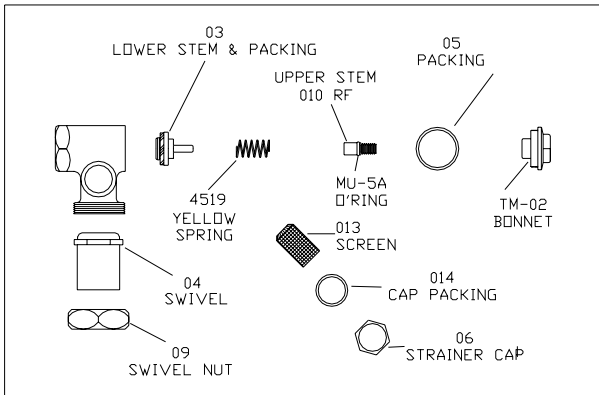

## LOCK-TYPE POINTER

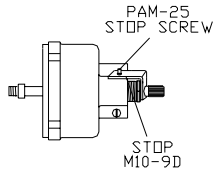

## REPAIR KITS

### KIT 1/28Y PACKINGS & GASKETS

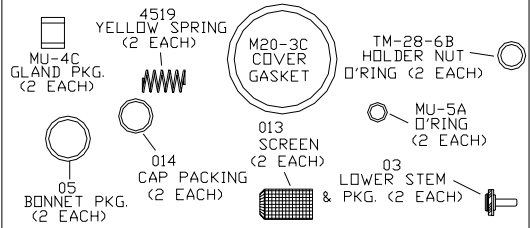

### KIT R/28 REBUILDING KIT

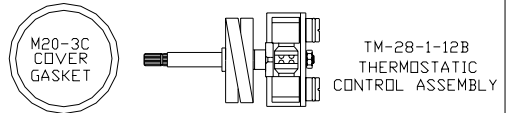

### KIT 2/28Y CHECKSTOP KIT

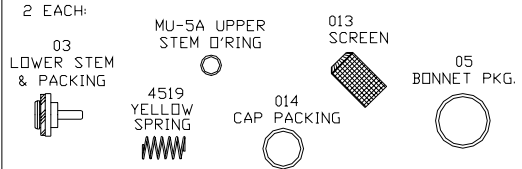

**REMEMBER!** THIS IS A CONTROL DEVICE WHICH MUST BE CLEANED AND MAINTAINED ON A REGULAR BASIS (SEE MAINTENANCE GUIDE AND RECORD)

**NOTE:** AFTER INSTALLING NEW PARTS IT WILL BE NECESSARY TO RESET THE ADJUSTABLE HIGH TEMPERATURE LIMIT STOP ON EACH VALVE (SEE PAGE 2).



## OPTIONAL OUTLET SETUP PIPING (BY OTHERS)

The addition of this piping arrangement (extra tee and ball valve) eliminates the need to turn showers on and off throughout the building at setup. The flows required in the setup instructions (page 3) are set by using Ball Valve A. (make sure main outlet ball valve is closed).

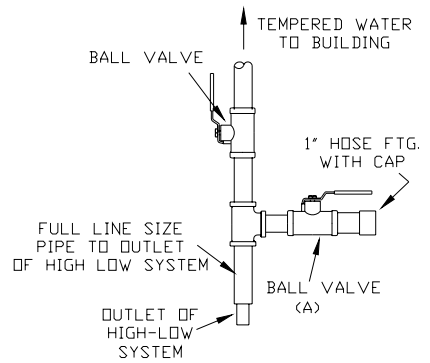

**CAUTION! ALL THERMOSTATIC WATER MIXING VALVES AND SYSTEMS HAVE LIMITATIONS! THEY WILL NOT PROVIDE THE DESIRED PERFORMANCE OUTSIDE OF THEIR FLOW CAPACITY RANGE! CONSULT THE CAPACITY CHART BELOW AND OBSERVE MINIMUM FLOWS SHOWN.**

## FLOW CAPACITIES

MINIMUM FLOW (GPM) (l/min)	SYSTEM PRESSURE DROP (PSIG)										PSI
	5	10	15	20	25	30	35	40	45	50	
	.3	.7	.97	1.4	1.7	2.1	2.4	2.8	3.1	3.4	BAR
1.0 (3.8)	78 295	113 428	129 488	145 549	163 617	172 651	188 712	197 746	214 810	226 856	GPM l/min

## LIMITED WARRANTY

Leonard Valve Company warrants the original purchaser that products manufactured by them (not by others) will be free from defects in materials and workmanship under normal conditions of use, when properly installed and maintained in accordance with Leonard Valve Company's instructions, for a period of one year from date of shipment. During this period the Leonard Valve Company will at its option repair or replace any product, or part thereof, which shall be returned, freight prepaid, to the Leonard factory and determined by Leonard to be defective in materials or workmanship. There are no warranties, express or implied, which extend beyond the description contained herein. There are no implied warranties of merchantability or of fitness for a particular purpose. In no event will Leonard be liable for labor or incidental or consequential damages. Any alteration or improper installation or use of the product will void this limited warranty.