

INSTALLATION, ADJUSTMENT, SERVICE MODEL 108, 220, 320 THERMOSTATIC / POINT OF USE MIXING VALVES

108 (3/8" COMP)*

220 (1/2" NPT)**

320 (3/4" NPT)**



*ASSE 1016 LISTED

INSTALLATION

**ASSE 1017 LISTED

WARNING: DO NOT USE THREAD SEALANT ON COMPRESSION CONNECTIONS

1. Valve should be installed where it can be easily cleaned, adjusted or repaired.
2. Inlets are furnished with NPT connections. When soldering close to this unit, **DO NOT OVERHEAT**, internal components may become damaged.
3. Leonard recommends that unions and shutoffs are installed on the inlets and outlet.
4. Use solder or pipe cement sparingly. Supply pipes should be flushed before the valve is connected. Flush outlet pipe and valve as soon as it is connected.

Maximum Operating Pressure: 125 PSI (860 KPA)



WARNING!!



WATER TEMPERATURES IN EXCESS OF 110°F (43°C) MAY CAUSE SCALDING, SEVERE INJURY, OR DEATH!!

IMPORTANT! These thermostatic water mixing valves can be adjusted to deliver water at temperatures exceeding 110°F (43°C). After installation, the installer must check the outlet water temperature and adjust the temperature setting to ensure delivery of a safe water temperature not exceeding 110°F (43°C). See "Temperature Adjustment" next page.

IMPORTANT!! THIS IS A CONTROL SYSTEM WHICH MUST BE CLEANED AND MAINTAINED ON A REGULAR BASIS (SEE MAINTENANCE GUIDE AND RECORD MGR-1001).

1360 Elmwood Avenue, Cranston, RI 02910 USA
Phone: 401.461.1200 Fax: 401.941.5310
Email: info@leonardvalve.com
Web Site: <http://www.leonardvalve.com>

ADJUSTMENT AND SERVICE

TEMPERATURE ADJUSTMENT

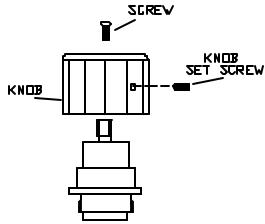

1. Open hot and cold water supply valves to mixing valve.
2. Open mixed water outlet.
3. With the fixture in the full open position, calibrate the mixed water outlet temperature by placing a thermometer in the mixed water stream. Loosen knob set screw with 5/64" allen wrench. Adjust the setting of the valve to obtain the desired temperature (counterclockwise, to increase temperature-clockwise to decrease temperature.)
4. Tighten knob set screw to lock temperature setting.



WARNING



WARNING! This thermostatic mixing valve's temperature setting **MUST** be checked. If the temperature is too high (above 110°F, 43°C), the temperature knob must be adjusted immediately. Excessively hot water is **DANGEROUS AND MAY CAUSE SCALDING!!**

PRESSURE-TEMPERATURE:

Maximum Supply Pressure: 125 psi (8.6 bar)
 Temperatures Range: Hot: 120°F to 180°F (49°C to 82°C)
 Cold: 39°F to 85°F (4°C to 29°C)
 Minimum Temperature Differential : 15°F (-9°C)

TROUBLESHOOTING INSTRUCTIONS

GASKET KIT	Leaking water under knob. Leaking water between valve cover and body.	GASKET KIT FOR 108, 220, 320 1/ WX
REBUILDING KIT	Valve will not control temperature after cleaning.	REBUILDING KIT FOR 108, 220, 320 R/ WX
CHECKSTOP KIT	Hot water by-pass into cold line. Cold water by-pass into hot line.	CHECK KIT Model 108 4/108 Model 220 4/220 Model 320 4/320

SEE PAGE 3 FOR COMPLETE PARTS BREAKDOWN

SEE PAGE 4 FOR PIPING IN RECIRCULATED OR NON-RECIRCULATED WATER SYSTEMS

MODEL	IN	OUT	MINIMUM FLOW (GPM)	PRESSURE DROP											PSI
				5	10	15	20	25	30	35	40	45	50	BAR	
108	3/8"	3/8"	LMIN	.3	.7	1.0	1.4	1.7	2.1	2.4	2.8	3.1	3.4		
			GPM	0.5	2.5	3.0	3.7	4.5	5.0	5.5	6.0	6.5	7.0	7.5	
220	1/2"	1/2"	LMIN	1.9	9.5	11.5	14	17	19	21	23	25	27	28	
			GPM	0.5	3.5	5.5	6.5	7.5	8.5	9.5	10	10.5	11.5	12	
320	3/4"	3/4"	LMIN	1.9	13	21	25	28	32	36	38	40	43	45	
			GPM	0.5	4	6	7	8	9	10	10.5	11.5	12.5	13	
			LMIN	1.9	15	23	27	30	34	38	40	43	47	49	

IMPORTANT!! THIS IS A CONTROL SYSTEM WHICH MUST BE CLEANED AND MAINTAINED ON A REGULAR BASIS (SEE MAINTENANCE GUIDE AND RECORD MGR-1001).

1360 Elmwood Avenue, Cranston, RI 02910 USA

Phone: 401.461.1200 Fax: 401.941.5310

Email: info@leonardvalve.com

WEB: <http://www.leonardvalve.com>

VALVE PARTS LIST

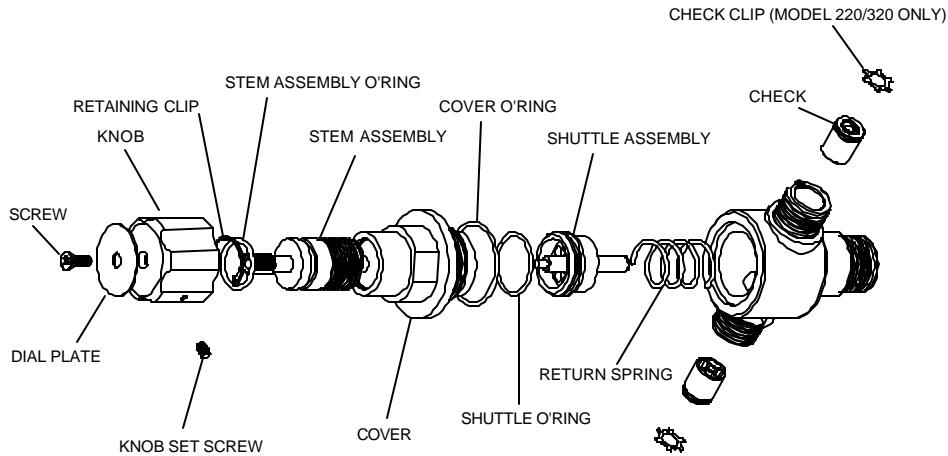

MODEL 108, 220, 320

1/ WX Gasket Kit Shuttle o'ring Stem assembly o'ring Cover o'ring	R/ WX Complete Rebuild Kit Return spring Shuttle assembly Shuttle o'ring Stem assembly o'ring Cover o'ring	MODEL 108 4/108 Check valve Kit 2 Check valve assembly	MODEL 220 4/220 Check valve Kit 2 Check valve assembly 2 Check clips
		MODEL 320 4/320 Check valve Kit 2 Check valve assembly 2 Check clips	

DISMANTLING & CLEANING

1. Shut off hot and cold water to the valve as well as the valve outlet port.
2. Loosen lock screw on side of knob with 5/64" allen wrench.
3. Remove the knob screw on top of knob.
4. Remove temperature adjustment knob.
5. Remove valve cover, which includes the stem assembly.
6. The shuttle assembly can now be removed, cleaned and inspected. Be sure to check the condition of the shuttle o-ring and replace if necessary.
7. Lubricate the shuttle o-ring before installing the shuttle assembly.
8. Install the cover assembly including o-ring back onto valve and tighten.
9. Replace knob and knob screw.
10. **Valve temperature must be reset after any repairs or cleaning!! See Page 2. Temperature Adjustment**

TROUBLESHOOTING

1. Leaking water under knob, order gasket kit, replace stem assembly o-ring. Remove knob screw and knob, remove retaining clip, thread out the stem assembly and replace o-ring. Lubricate o-ring, thread stem into cover, replace retaining ring, knob and screw. **Valve temperature must be reset after any repairs or cleaning!! See page 2.**
2. Leaking water between cover and body, order gasket kit, replace cover o-ring. Remove knob screw and knob and remove valve cover and replace o-ring. Replace valve cover, knob and knob screw. **Valve temperature must be reset after any repairs or cleaning!! See page 2.**
3. Hot water bypass into cold line, order checkstop kit and replace checks within inlets of valve.
4. Valve not controlling temperature even after cleaning, order complete rebuild kit. Remove knob screw and knob and remove valve cover. Replace shuttle assembly and return spring being sure to lubricate shuttle o-ring. Replace valve cover, knob and knob screw. **Valve temperature must be reset after any repairs or cleaning!! See page 2.**

IMPORTANT!! THIS IS A CONTROL SYSTEM WHICH MUST BE CLEANED AND MAINTAINED ON A REGULAR BASIS (SEE MAINTENANCE GUIDE AND RECORD MGR-1001).

1360 Elmwood Avenue, Cranston, RI 02910 USA

Phone: 401.461.1200 Fax: 401.941.5310

Email: info@leonardvalve.com

WEB: <http://www.leonardvalve.com>

INSTALLATION WITHOUT CIRCULATED TEMPERED WATER

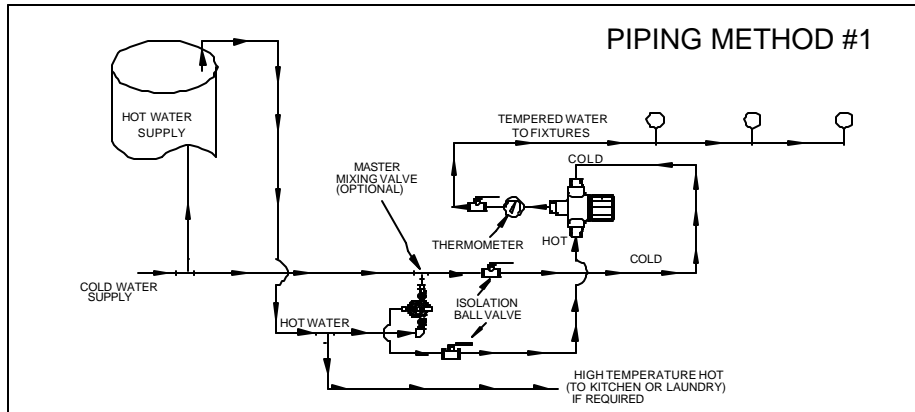

1. Model 108, 220 and 320 Thermostatic Mixing Valves must be installed according to Piping Diagram #2A if recirculation of tempered water is required.
2. The 108, 220 and 320 Thermostatic Mixing Valve should be installed below the hot water tank. If the valve cannot be located in this area, the hot water inlet piping to the mixing valve should be installed with a heat trap.

INSTALLATION WITH CIRCULATED TEMPERED WATER

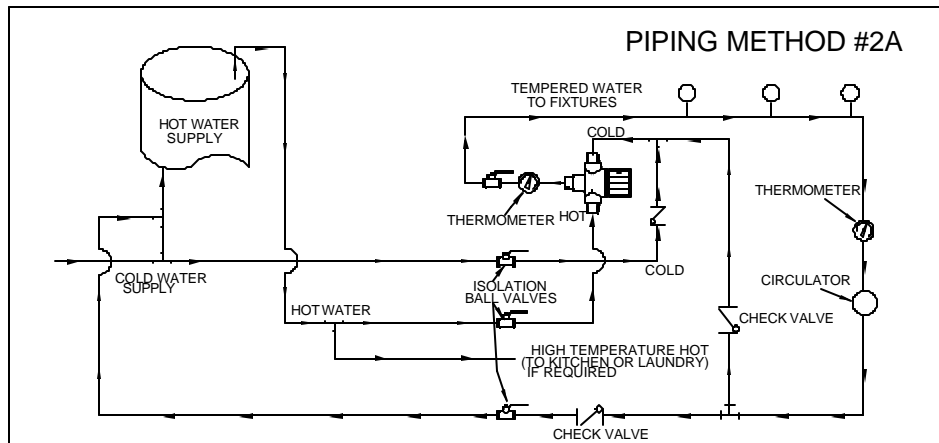

LIMITED WARRANTY

Leonard Valve Company warrants the original purchaser that products manufactured by them (not by others) will be free from defects in materials and workmanship under normal conditions of use, when properly installed and maintained in accordance with Leonard Valve Company's instructions, for a period of one year from date of shipment. During this period the Leonard Valve Company will at its option repair or replace any product, or part thereof, which shall be returned, freight prepaid, to the Leonard factory and determined by Leonard to be defective in materials or workmanship. There are no warranties, express or implied, which extend beyond the description contained herein. There are no implied warranties of merchantability or of fitness for a particular purpose. In no event will Leonard be liable for labor or incidental or consequential damages. Any alteration or improper installation or use of the product will void this limited warranty.

1360 Elmwood Avenue, Cranston, RI 02910 USA
 Phone: 401.461.1200 Fax: 401.941.5310
 Email: info@leonardvalve.com
 WEB: <http://www.leonardvalve.com>