

**MEGATRON[®] MODEL PNV-200-LF
DIGITAL TEMPERATURE
CONTROL STATION**

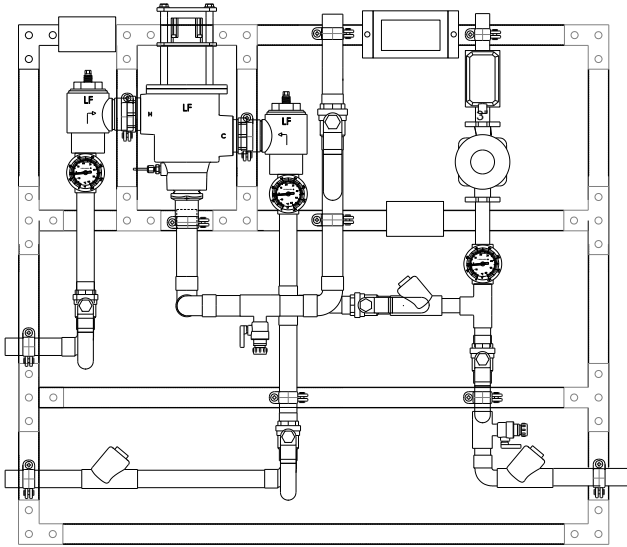

- Digital Mixing Valve with 2" inlet angled check stops, 2" Outlet and integral RTD Sensor
- 2" NPT inlets, 2" NPT outlet (51mm X 51mm), 1-1/4" return
- 0.25 GPM** (0.95 L/min) minimum flow capacity
- Maximum operating pressure: 125 PSIG (869 KPA)
- Controls water temperature to $\pm 2^{\circ}\text{F}$ in accordance with ASSE 1017
- Controls water temperature to $\pm 2^{\circ}\text{F}$ during times of low / no system demand
- Automatic Hot/Cold Water shutoff upon cold/ hot water inlet supply failure
- Self-Balancing - No need to manually adjust or balance recirculation
- Self-Cleaning - Daily shuttle sweep keeps shuttle free of debris
- Alerts user when unit requires maintenance
- Displays outlet temperature
- Simple user programmable set point, range between 65°F and 180°F
- UL Listed Control Box
- UL Listed 120V plug in power supply with 6' cord
 - Option for Backup Uninterruptable Power Supply in the event of primary power loss w/ approx. two hours run time
- Factory assembled and tested

****NOTE:** The valve will maintain temperature with 0.25 GPM flow from the domestic hot water loop when properly installed near the hot water source with a continuously operating recirculation pump. Factory supplied circulator standard with Taco 0013.

Valve is ASSE 1017 Certified



Valve is CSA Certified



Valve electronics are UL Certified



See Page 2 for Specification Detail, Page 4 for Piping Method Detail & Flow Capacity Chart, Pages 5 and 6 for Options

See Page 7 for Digitally Enhanced Megatron Proton

This product meets Low Lead requirements of wetted surface area containing less than 0.25% lead by weight

Product is non-cancellable and non-returnable from date of order with factory. Signed submittal required with purchase order.



WARNING: This product can expose you to chemicals including lead, which is known to the State of California to cause cancer. For more information, go to www.P65Warnings.Ca.gov



1360 Elmwood Avenue, Cranston, RI 02910 USA

Phone: 401.461.1200 Fax: 401.941.5310

Email: info@leonardvalve.com

Web Site: <http://www.leonardvalve.com>

LEONARD MEGATRON® MODEL PNV-200-LF

Complete Digital Water Temperature Control Station to include:

- 2" inlet connections (copper tube)
- 2" outlet connection (copper tube)
- 1-1/4" return connections (copper tube)
- Leonard Proton Digitally Controlled Mixing Valve with simple two line LED display
- Leonard Factory check valves and full port ball valves on inlet piping
- Outlet Test Connection with ball valve and 3/4" connection
- Full port ball valve mounted downstream of test connection on mixed water outlet of the system
- Subassembly with 1-1/4" return piping, Aquastat, circulator, full port ball valves and check valves
- Aquastat with temperature differential of 5 to 30°F (3 to 17°C)
- Two GFCI* switches. The circulator GFCI switch will be used to turn the circulator on or off for setup *Ground Fault Circuit Interrupter*
- System mounted on struts, galvanized. Struts shall be assembled with three hole flat angle plate on corners, four hole tee plates or two hole flat plate connectors on all other support pieces using 3/8" grip lock nuts and 3/8" x 1" hex head cap screws, washers and lock washers
- All electrical connections to be completed by Electrical Contractor



1360 Elmwood Avenue, Cranston, RI 02910 USA

Phone: 401.461.1200 Fax: 401.941.5310

Email: info@leonardvalve.com

Web Site: <http://www.leonardvalve.com>

LEONARD MEGATRON® MODEL PNV-200-LF DIGITAL TEMPERATURE CONTROL STATION

Image not to scale, Dimensions will vary with any options

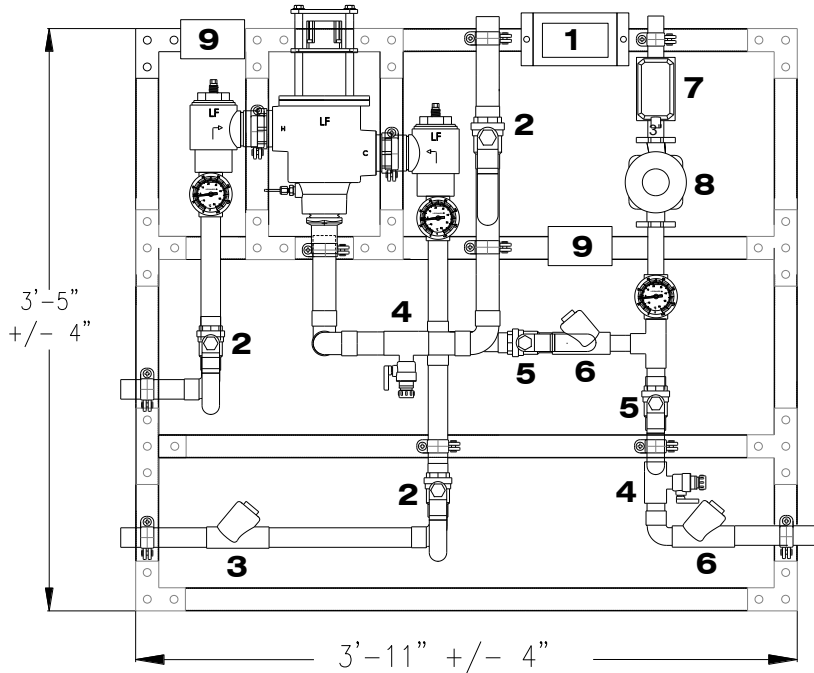

1. PROTON VALVE AND CONTROLS
2. 2" FULL PORT BALL VALVE
3. 2" CHECK VALVE
4. 3/4" TEST CONNECTION
5. 1-1/4" FULL PORT BALL VALVE

6. 1-1/4" CHECK VALVE
7. AQUASTAT
8. CIRCULATOR
9. GFCI ELECTRICAL OUTLET

PROTON VALVE CONTROL BOX



1360 Elmwood Avenue, Cranston, RI 02910 USA

Phone: 401.461.1200 Fax: 401.941.5310

Email: info@leonardvalve.com

Web Site: <http://www.leonardvalve.com>

MEGATRON® MODEL PNV-200-LF 1-1/4" RETURN PIPING METHOD W

Image not to scale

HIGH TEMPERATURE FIXTURES (IF APPLICABLE)

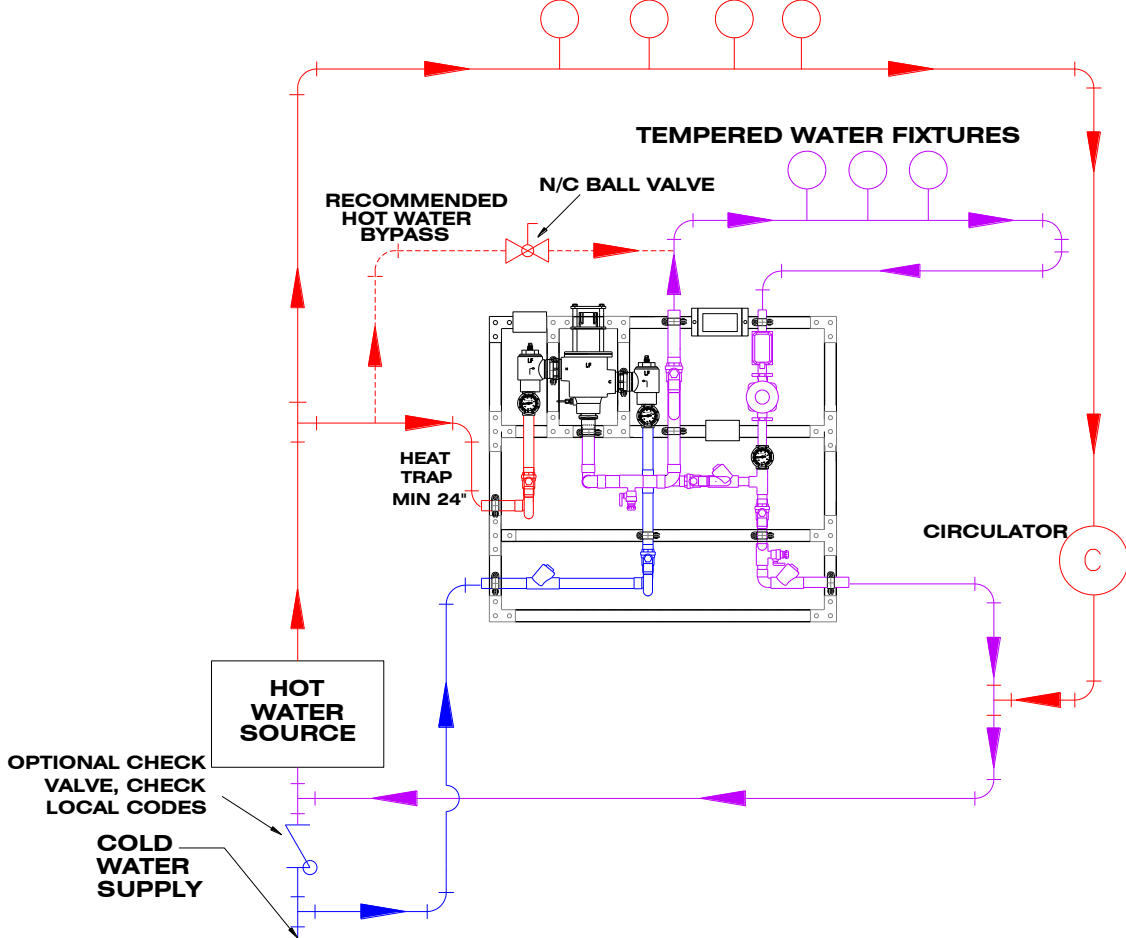

MINIMUM FLOW (GPM) (l/min)	PRESSURE DROP										PSI BAR
	5	10	15	20	25	30	35	40	45	50	
0.25** (.95)	80	115	130	147	165	173	189	198	215	226	GPM l/min
	303	435	492	556	625	655	715	750	814	856	

NOTE: Flowrates will vary depending on existing field conditions. Leonard Valve Company always recommends using CASPAK® sizing software for proper valve sizing and model number applications.



1360 Elmwood Avenue, Cranston, RI 02910 USA
Phone: 401.461.1200 Fax: 401.941.5310

Email: info@leonardvalve.com

Web Site: <http://www.leonardvalve.com>

OPTIONS

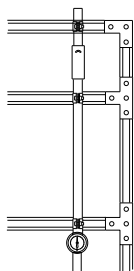

LC

Megatron® furnished without a circulator.

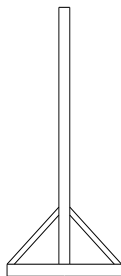

FM

Megatron® with 3 legs, 3 ½” feet and 45 degree braces front and back for mounting to floor in center of room.

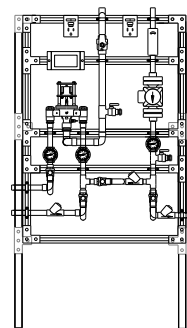

FS

Megatron® with separate legs to floor to support the unit without hangers.

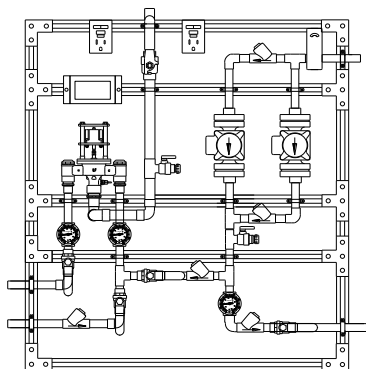

2 PUMPS R

Redundant recirculation pump

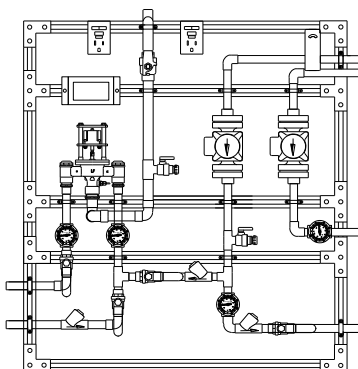

2 PUMPS H

High temperature loop recirculation pump

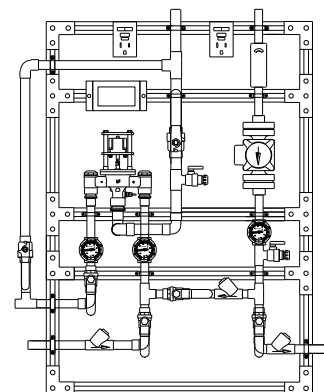

HBP

High temperature by-pass flush with locking ball valve

OPTIONS *

- LC** Less circulator
- FM** Floor mount
- FS** Free standing
- 2 PUMP R** Redundant recirculator pump
- 2 PUMP H** High temperature loop recirculator pump
- HBP** High temperature by-pass flush
- 265-1** Timer, Analog, 24 hour
- 265-3** Timer, Digital, 7 day
- HOA** HOA switch

OPTIONS (shown on next page) *

- AL** Audio Visual Alarm
- RDU** Remote Display Unit
- SCO** Solenoid Control Option
- IOT** Modbus to Wifi gateway
- BPS** Back up Power Supply
- DA** Digital Aquastat
- DG** Digital Gauges
- TACO 0034EPLUS** Smart pump
- Pump less aquastat – no price increase
- Pump with aquastat – with price increase
- DEMP** Digitally Enhanced Megatron Proton, Aquastat, Gauges and Digital pump
- User chosen pump** (specify on next page)

PIPING OPTIONS *

- RP 1-1/2** 1-1/2” Return line size
- RP 2** 2” Return line size

* Any option chosen will alter pricing



1360 Elmwood Avenue, Cranston, RI 02910 USA
 Phone: 401.461.1200 Fax: 401.941.5310
 Email: info@leonardvalve.com
 WEB: <http://www.leonardvalve.com>



OPTION AL: Leonard Single Probe Digital Temperature Alarm

- Single Point Temperature Probe - Range: -148°F to 212°F Resolution: 1°F
- User adjustable high & low set points and initial alarm delay period
- Audible & visual alarms
- Remote alarm contacts (SPDT) with adjustable relay delay period
- AL option replaces analog outlet dial thermometer with a single digital display



OPTION RDU: Leonard Remote Display Unit

- Activation by Primary Alarm's (pictured above) remote alarm contacts
- Alarm Delay Module with yellow, red, green LED indicators
- Recommended maximum distance from controller to RDU is 500'



SCO: Solenoid Control Option

- For use with Alarm relay switch
- Galvanized box with dimensions 6" Wide x 6" High x 4" Deep
- Solid state relay and terminal strip mounted and wired
- UL listed 100-240VAC power supply with 10' cord
- For either normally open or normally closed operation
- For use with 24-240 VAC solenoids only

IOT: Internet of Things

- Modbus to Wi-Fi gateway that connects to the Cloud to allow online monitoring of outlet temperature and Modbus connectivity to BMS



BPS: Backup Power Supply

- Uninterruptable Power Supply with up to 2 hours run time in case of primary power loss



OPTION DA: Digital Aquastat

- Electronic digital aquastat with Nema 1 case and SPDT Relay Output, replaces standard aquastat



OPTION DG: Digital Gauges

- Replaces all analog gauges with digital gauges, inlet hot, inlet cold, outlet and return temperature



OPTION TACO 0034E PLUS: ECM High-Efficiency Circulator

- High-performance, variable speed, wet-rotor circulator with high-efficiency ECM permanent magnet technology, Simple 3-button control, replaces standard Taco 0013
- An intuitive digital user interface lets you choose between a variety of operating modes; activeADAPT™, five Constant Pressure curves, five Proportional Pressure curves, Min/Max fixed speed or speed control through 0-10V DC or PWM external input
- Digital LED screen displays; Watts, GPM, Head, RPM and diagnostic error codes
- Maximums of 34 feet of head and 50 GPM

OPTION DEMP: Digitally Enhanced Megatron Proton – shown next page

- Includes DA, DG and TACO 0034E PLUS digital options all in one package

OPTION



USER CHOSEN PUMP

Standard pump is Taco 0013, if another manufacturer is preferred please specify, but note that ANY change from standard pump will result in a **PRICE INCREASE**

1360 Elmwood Avenue, Cranston, RI 02910 USA

Phone: 401.461.1200 Fax: 401.941.5310

Email: info@leonardvalve.com

Web Site: <http://www.leonardvalve.com>

Digitally Enhanced Megatron Proton

Below shown with DEMP option package

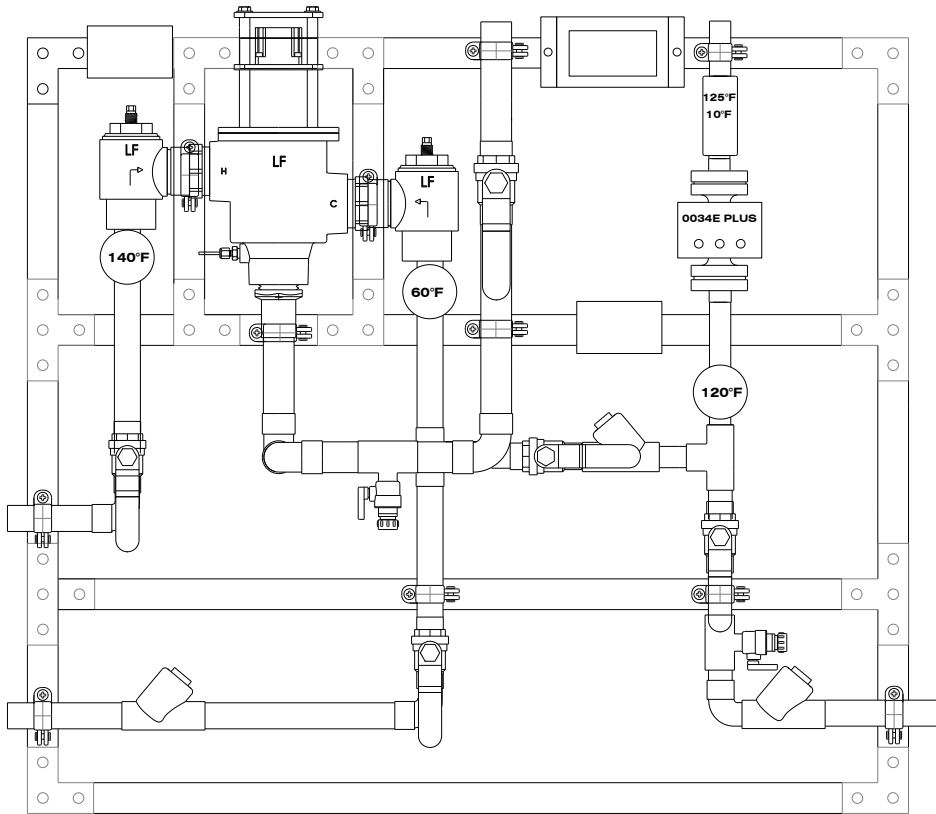

Digitally Enhanced Megatron Proton includes DEMP Option package,

Digital Aquastat

- Electronic digital aquastat with Nema 1 case and SPDT Relay Output, replaces standard aquastat

Digital Gauges

- Replaces all analog gauges with digital gauges, inlet hot, inlet cold, outlet and return temperature

TACO 0034E PLUS: ECM High-Efficiency Circulator

- High-performance, variable speed, wet-rotor circulator with high-efficiency ECM permanent magnet technology, Simple 3-button control, replaces standard Taco 0013
- An intuitive digital user interface lets you choose between a variety of operating modes; activeADAPT™, five Constant Pressure curves, five Proportional Pressure curves, Min/Max fixed speed or speed control through 0-10V DC or PWM external input
- Digital LED screen displays; Watts, GPM, Head, RPM and diagnostic error codes
- Maximums of 34 feet of head and 50 GPM



1360 Elmwood Avenue, Cranston, RI 02910 USA

Phone: 401.461.1200 Fax: 401.941.5310

Email: info@leonardvalve.com

Web Site: <http://www.leonardvalve.com>