

# THERMOSTATIC MIXING VALVE

## ECO-MIX™

# MODEL 270-LF

**LEAD FREE THERMOSTATIC POINT OF USE MIXING VALVE**  
MODEL 1/2" inlets, 1/2" outlet, (MIPS connections)

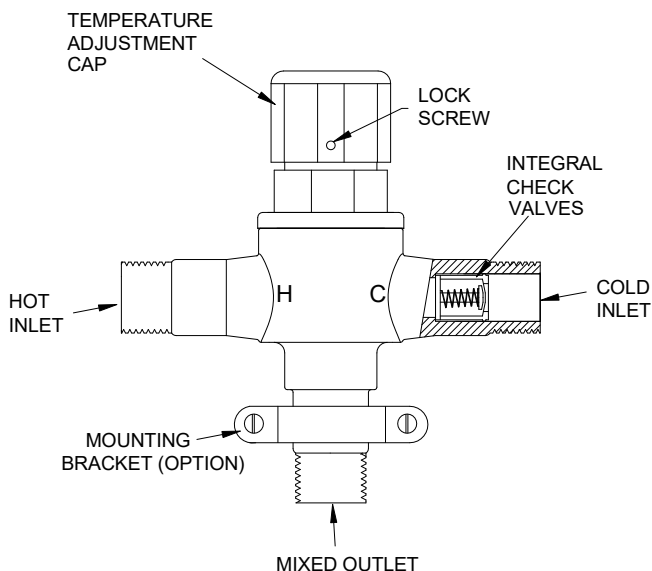
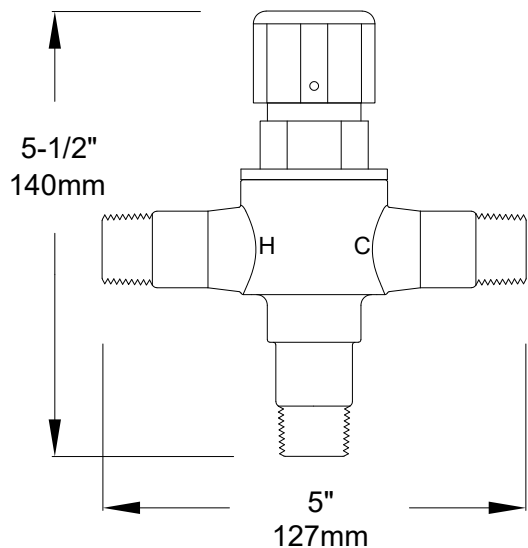

### MATERIALS:

- Lead Free Bronze body
- Locked temperature adjustment cap (vandal resistant)
- Copper encapsulated thermostat assembly with polymer thermoplastic shuttle
- Stainless steel springs
- Integral check valves on hot and cold inlets

### PRESSURE-TEMPERATURE:

- Minimum Flow: 0.25 GPM (0.95 l/Min)\*
- Maximum Pressure: 125 PSI (8.6 BAR)
- Maximum Hot Water temperature: 200°F- (93°C)
- Approach Temperature 5°F (2.8°C) above set point.
- Temperature adjustment range, 90-140°F (32-60°C) \*\*

### OPTIONS:

- \_\_\_ SUFFIX BRKT – Mounting Bracket (Shipped Loose)
- \_\_\_ SUFFIX BV – Ball Valves, 3 included (Shipped Loose)
- \_\_\_ SUFFIX SW – Sweat Connections, 3 included (Shipped Loose)
- \_\_\_ SUFFIX CP – Chrome Plated
- \_\_\_ SUFFIX DT – Dial Thermometer and Tee (Shipped Loose)
- \_\_\_ SUFFIX PEX – F1807 Pex Adapters, union style, 3 included (Shipped Loose)

### Certifications:

ASSE 1017, 1070



CSA



CUPC



**Certified to NSF61 thru the ASSE 1070 testing process**

This product is certified to meet Low Lead requirements of wetted surface area containing less than 0.25% lead by weight

**\*\*NOTE:** For temperatures outside of this valve's stated range, please see our line of bi-metal valves.



**WARNING:** This product can expose you to chemicals including lead, which is known to the State of California to cause cancer. For more information, go to [www.P65Warnings.Ca.gov](http://www.P65Warnings.Ca.gov)

\* 0.25 GPM minimum flow certified to ASSE 1070

PRESSURE DROP						
5	10	20	30	40	50	PSI
.35	.70	1.4	2.1	2.8	3.4	BAR
3.5	5.5	7.5	9.5	10.5	12	GPM
13	21	28	36	40	45	l/min

<b>Engineer's Approval</b>	Job # _____
	Arch/Eng. _____
	Contractor _____



1360 Elmwood Avenue, Cranston, RI 02910 USA  
Phone: 401.461.1200 Fax: 401.941.5310

Email: [info@leonardvalve.com](mailto:info@leonardvalve.com)

Web Site: <http://www.leonardvalve.com>