

# INSTALLATION ADJUSTMENT SERVICE PROTON PLUS VALVE

**IMPORTANT! Provide serial number when ordering parts!!**

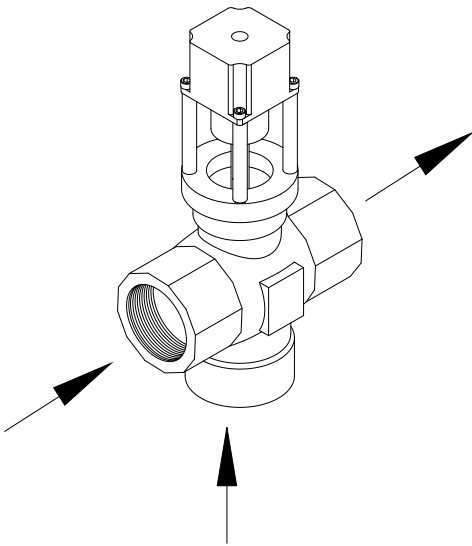

**WARNING:** This product can expose you to chemicals including lead, which is known to the State of California to cause cancer. For more information, go to [www.P65Warnings.Ca.gov](http://www.P65Warnings.Ca.gov)



**INSTALLATION AND FIELD ADJUSTMENT OF THE DEVICE ARE THE RESPONSIBILITY OF THE INSTALLER AND SHALL BE CARRIED OUT IN ACCORDANCE WITH THE MANUFACTURER'S INSTRUCTIONS**



- |   |   |
|---|---|
| <ol style="list-style-type: none"> <li>Leonard Proton Plus Valves are factory pre-assembled and tested and include digital mixing valve and controls which function as a system to meet both high and low demand for tempered water.</li> <li>System should be installed at a location where it can easily be cleaned, adjusted or repaired.</li> <li>System supplies must be connected as shown on page 2.</li> <li>Flush pipes thoroughly after system has been connected.</li> </ol> | <ol style="list-style-type: none"> <li>This assembly <b>MUST</b> be piped according to <b>LEONARD'S REQUIRED PIPING METHOD W</b>, see page 2.</li> <li>Refer to pages starting on page 2 of this bulletin for correct Setup Instructions.</li> <li><b>Suitable for indoor use only</b></li> <li>Not for use in process applications, install as an ASSE 1017 master mixer in a domestic hot water system that includes other mixing devices approved to ASSE 1016, 1069, 1070, and 1071.</li> </ol> |
|---|---|

**Model PPV-075-LF – 3/4" NPT Female Inlets and Outlet**

**Model PPV-100-LF – 1" NPT Female Inlets and Outlet**

**Model PPV-125-LF – 1-1/4" NPT Female Inlets and Outlet**

**Model PPV-150-LF – 1-1/2" NPT Female Inlets and Outlet**

**Model PPV-200-LF – 2" NPT Female Inlets and Outlet**

**Inlet Check valves are required to prevent cross flow on all models**

**Maximum Operating Pressure 200PSI (13.8 BAR), valve only**

**Hot Water Temperature Range: 120° - 180°F (49° - 82°C)**

**Cold Water Temperature Range: 35° - 80°F (2° - 27°C)**

**Temperature Adjustment Range: 95° - 160°F (35° - 71°C)**

**Temperature sensor is shipped loose and must be installed by contractor, see page 2**

1360 Elmwood Avenue, Cranston, RI 02910 USA

Phone: 401.461.1200 Fax: 401.941.5310

Email: [info@leonardvalve.com](mailto:info@leonardvalve.com)

Web Site: <http://www.leonardvalve.com>