

EMERGENCY MIXING VALVES

ECO-MIX™

Mixing Valve for Drench or Combination Emergency Shower

3 - 126 GPM (11 -477 l/min) flow rate
up to 45 PSI (3.1 bar) system pressure drop

TM-5100-LF

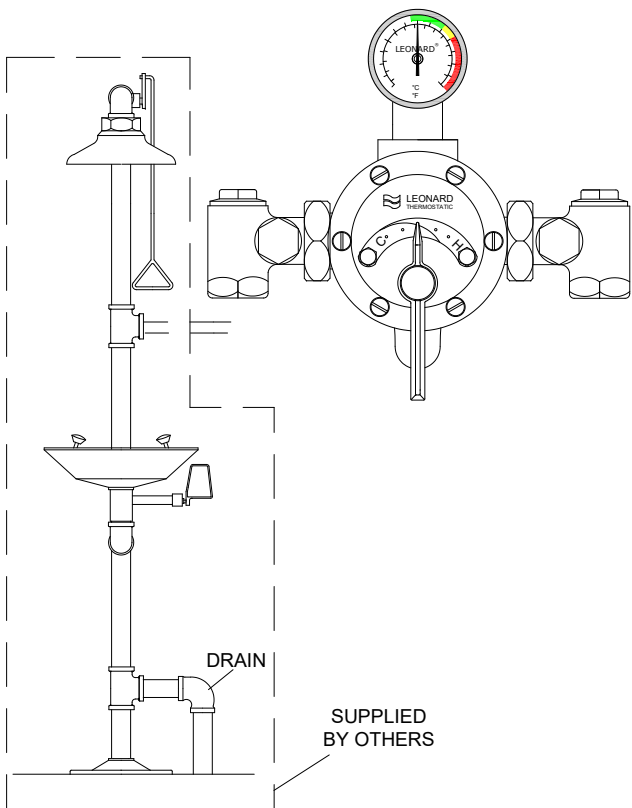

- DURA-trol® solid bimetal thermostat directly linked to valve porting to control the intake of hot and cold water and compensate for supply temperature and pressure fluctuations. DURA-trol is highly responsive and cannot be damaged by extremes in temperature
- Thermostatic Mixing Valve can be set to the correct temperature for the application
- Locking type temperature regulator to prevent accidental movement set for 85°F (29°C)
- Mixing valve will close down on failure of cold water supply
- Mixing Valve with special internal cold water bypass capable of a minimum of 40 GPM (151 l/min) @ 30 PSI (2.1 Bar) upon failure of hot water supply
- Adjustable high temperature limit stop * set for 90°F (32°C)
- 1-1/4" top or bottom inlets, NPT Female & 1-1/2" top outlet, NPT Female
- Integral wall support
- Dial thermometer (range 0 to 140°F, -10 to 60°C)
- Rough bronze finish
- Union angle checkstops on inlets
- Compliance.....ANSI Z358.1
- Maximum supply temperature 180 °F (82°C)
- Maximum supply pressure 125 PSI (8.6 Bar)

This product is certified to meet Low Lead requirements of wetted surface area containing less than 0.25% lead by weight

NOTE: Performance specifications above applicable when valve is tested to conditions specified per ASSE 1071

OPTIONS:

- CP- Chrome plated finish
- IT- Inlet thermometers (range 0 to 140°F, -10 to 60°C)

CABINET OPTIONS – SEE PAGE 3

Buy American Act
COMPLIANT

BUILD AMERICA BUY AMERICA
COMPLIANT



WARNING: Risk of cancer and reproductive harm from exposure to lead – See

www.P65Warnings.ca.gov

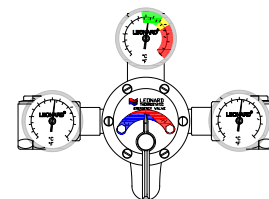

SUFFIX IT

| | |
|----------------------------|------------------|
| Engineer's Approval | Job # _____ |
| | Arch/Eng. _____ |
| | Contractor _____ |



***NOTE:** A limit stop, set for 90°F (32°C), is simply a mechanical setting to prevent excessive handle rotation. If incoming water is hotter than 135°F (57°C), the temperature of the factory test, the valve when turned to full HOT may deliver water in excess of 90°F and the limit stop **MUST BE RESET BY THE INSTALLER**

1360 Elmwood Avenue, Cranston, RI 02910 USA
Phone: 401.461.1200 Fax: 401.941.5310
Email: info@leonardvalve.com
Web Site: <http://www.leonardvalve.com>

EMERGENCY WATER MIXING VALVE FOR DRENCH OR COMBINATION EMERGENCY SHOWER

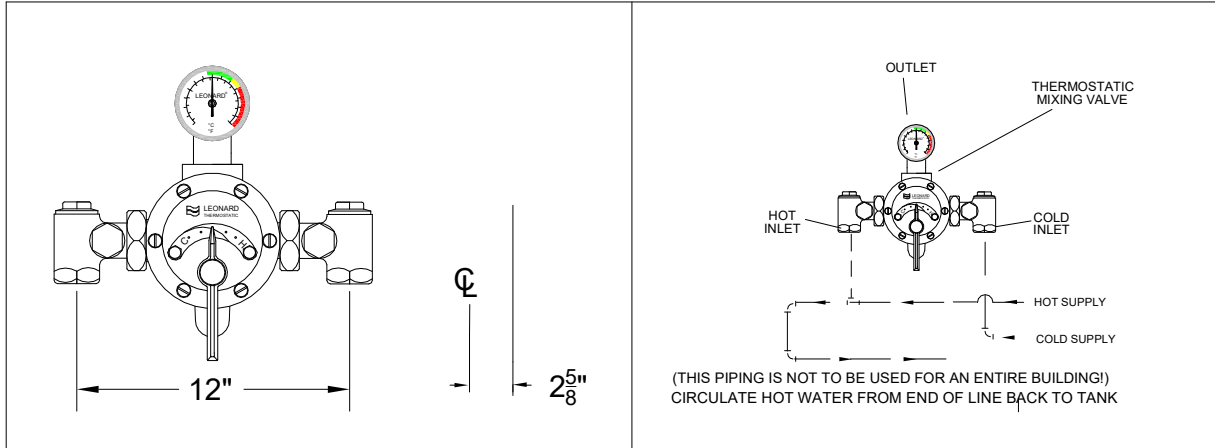

CAUTION! It may be necessary to recirculate the tempered water to the emergency shower should the piping be exposed to excessive hot or cold conditions. Consult factory for proper piping.

FLOW CAPACITIES

| MODEL | IN | OUT | MINIMUM FLOW (GPM) | INTERNAL COLD WATER BY-PASS | SYSTEM PRESSURE DROP | | | | | | | | | |
|-----------------------|--------|--------|--------------------|-----------------------------|----------------------|-----|-----|-----|-----|-----|-----|-----|-----|-------|
| | | | | | 5 | 10 | 15 | 20 | 25 | 30 | 35 | 40 | 45 | PSI |
| | | | L/MIN | | .3 | .7 | 1.0 | 1.4 | 1.7 | 2.1 | 2.4 | 2.8 | 3.1 | BAR |
| TM-5100 | 1 1/4" | 1 1/2" | 3 | 40 | 53 | 64 | 72 | 81 | 90 | 99 | 108 | 117 | 126 | GPM |
| | | | 11 | 151 | 201 | 242 | 273 | 307 | 341 | 374 | 409 | 443 | 477 | L/MIN |
| MAXIMUM FLOW CAPACITY | | | | | | | | | | | | | | |

The Emergency eye/face wash Mixing Valve shall control and maintain the temperature of the water to the station. Unit shall be self contained and include a thermostatic water mixing valve, a dial thermometer on the outlet, union angle checkstops, wall mounting bracket, piping and fittings factory assembled and tested, top or bottom inlets and top outlet, unit set for 85°F (29°C) and a maximum temperature of 90°F (32°C). Unit must be able to be set to the correct temperature for the specific contaminant but must be locked in place to prevent changing of the temperature by accident. Unit must be checked weekly for performance in conjunction with the requirements of ANSI Z-358.1. Unit shall be able to flow 40 GPM (151 l/min) at 30 PSI (2.1 Bar).

WARNING! IT IS THE RESPONSIBILITY OF THE SPECIFIER TO DETERMINE THE DELIVERED WATER TEMPERATURE TO EACH SAFETY FIXTURE. A COMFORTABLE RANGE IS 60°F TO 90°F (15° TO 32°C). IN CIRCUMSTANCES WHERE A CHEMICAL REACTION IS ACCELERATED BY WATER TEMPERATURE, A MEDICAL ADVISOR SHOULD BE CONSULTED FOR THE OPTIMUM TEMPERATURE FOR EACH APPLICATION.

Specifications are subject to change without notice!

CAUTION! All thermostatic water mixing valves have limitations. They will NOT provide the desired accuracy outside of their flow capacity range. Consult the Flow Capacity Chart and DO NOT OVERSIZE. Minimum flow must be no less than indicated.



1360 Elmwood Avenue, Cranston, RI 02910 USA

Phone: 401.461.1200 Fax: 401.941.5310

Email: info@leonardvalve.com

Web Site: <http://www.leonardvalve.com>

TM-5100-LF CABINET OPTIONS

**Viewport is standard
on all TM-5100
cabinets**

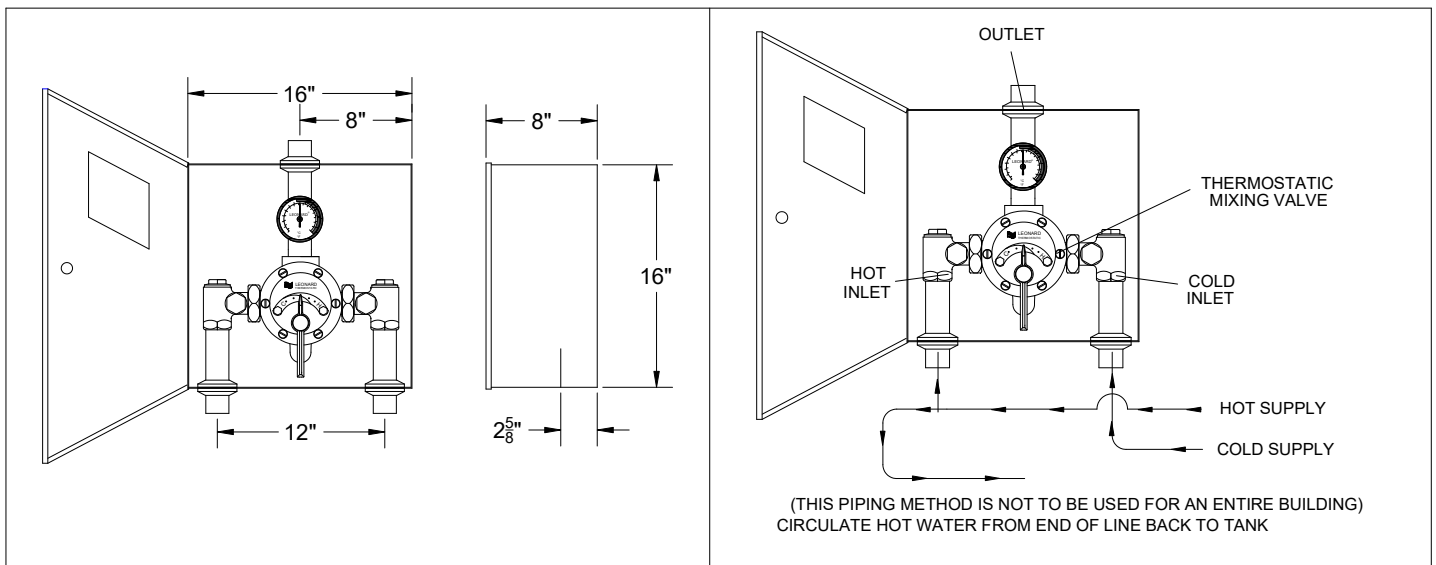
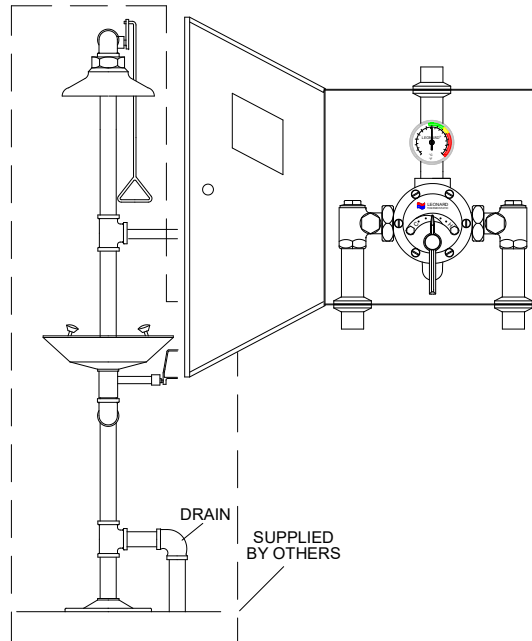

OPTIONS:

- ___ SUFFIX BWE REC- Steel cabinet, baked white enamel recessed
- ___ SUFFIX STSTL REC- Stainless Steel recessed cabinet
- ___ SUFFIX BWE EXP- Exposed cabinet, baked white enamel
- ___ SUFFIX STSTL EXP- Exposed cabinet, Stainless steel
- ___ SUFFIX SEMI- Semi-recessed frame 4" deep
- ___ SUFFIX IT- Inlet thermometers
- ___ SUFFIX TOP- Top inlets



NOTE: Leonard Valve Company reserves the right of product or design modification without notice or obligation

1360 Elmwood Avenue, Cranston, RI 02910 USA

Phone: 401.461.1200 Fax: 401.941.5310

Email: info@leonardvalve.com

Web Site: <http://www.leonardvalve.com>