

PROTON PLUS

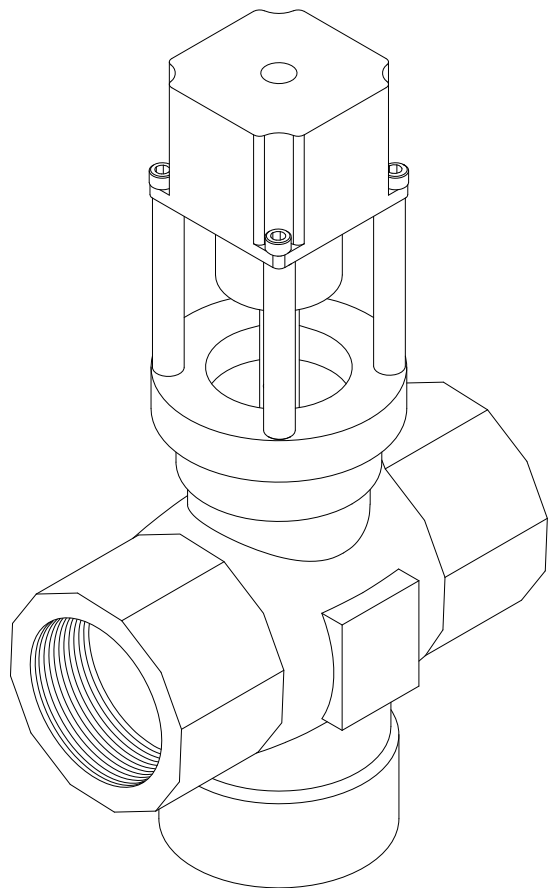

STANDARD CONTROL BOX
(see page 2 for more information)



- Digital Mixing Valve with integral RTD Sensor
- Sizes from 3/4" to 2", NPT female inlets and outlets
- Full stainless steel construction of valve body and all parts contacted by water
- Valve controls at times of no use, 0.0 GPM*
- Maximum operating pressure: 200 PSIG (1379 KPA)
- Controls water temperature to +/- 2°F in accordance with ASSE 1017
- Controls water temperature to +/- 2°F during times of low / no system demand
- Self-Balancing, do not need to adjust or balance recirculation
- Self-Cleaning, daily shuttle sweep keeps shuttle free of debris
- Automatic Hot / Cold Water shutoff upon cold / hot water inlet supply failure
- Alerts user when unit requires maintenance
- User programmable set point range between 95°F and 160°F, Displays outlet temperature
- Simple / intuitive user commissioning and setup
- ETL Listed control box and 120V plug in power supply with 6' cord, optional BPS below
- Suitable for indoor use only
- Not for use in process applications nor intended to deliver final temperature control
- Primary use as an ASSE 1017 Distribution Valve / Master Mixer in a Domestic Hot Water System when combined with proper downstream protection devices approved to ASSE 1016, 1069, 1070 or 1071

OPTIONS:

- ___ CV – Inlet check valves, shipped loose
- ___ BPS – Back-up Power Supply, uninterruptable power supply with up to 2 hours run time in case of primary power loss



***NOTE:** The valve will maintain temperature with 0.0 GPM flow from the domestic hot water loop when properly installed near the hot water source with a continuously operating recirculation pump, see minimum flow for minimum pump flow rate

This product is certified to meet Low Lead requirements of wetted surface area containing less than 0.25% lead by weight

Valve is ASSE 1017 Certified



Valve is CUPC Certified



Valve is NSF 61 Certified



Valve electronics are ETL Certified



1360 Elmwood Avenue, Cranston, RI 02910 USA
Phone: 401.461.1200 Fax: 401.941.5310
Email: info@leonardvalve.com
Web Site: <http://www.leonardvalve.com>

PROTON PLUS CONTROLLER



A = 8" B = 4-3/4"
Depth = 1-1/4"

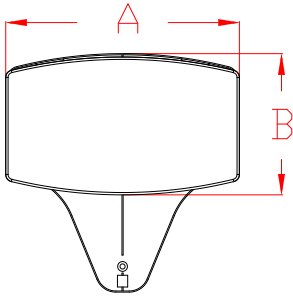

Enhanced Proton Plus Controller includes

- BACnet MS/TP or Modbus RTU Connection which provides ability to serve up all data to BMS system
- Wi-Fi – Wi-Fi enabled
- Programmable Disinfection Mode

Options:

 3T – Three Additional Temperature Sensors for Monitoring of Inlet Hot, Inlet Cold, and Return Temperatures

 REL – 5 Relay Contacts that Switch during Alarm State

- Helpful for Remote Alerts Within Building to Assist Maintenance and Service Personnel
- 5 Unique States:
 - Maintenance (Service Required)
 - “Out of Range” Temperature ($\pm 10^{\circ}\text{F}$)
 - Broken Temperature Probe
 - Motor Connectivity and Operation
 - Loss of Power

Leonard Valve Company reserves the right of product, or design modifications without notice or obligation.

© 2026 Leonard Valve Company
Printed in USA



1360 Elmwood Avenue, Cranston, RI 02910 USA
Phone: 401.461.1200 Fax: 401.941.5310
Email: info@leonardvalve.com
Web Site: <http://www.leonardvalve.com>

PROTON PLUS FLOW RATES

Valve size will most likely be less than inlet / outlet pipe sizes

		PRESSURE DROP (PSI)									
MODEL # Inlet/Outlet	Minimum Flow*	5 PSI	10 PSI	15 PSI	20 PSI	25 PSI	30 PSI	35 PSI	40 PSI	45 PSI	50 PSI
PPV075LF 3/4"	3 GPM	16	24	28	33	37	40	43	46	49	52
PPV100LF 1"	5 GPM	35	56	66	77	86	93	102	107	112	118
PPV125LF 1-1/4"	7 GPM	52	75	92	104	118	131	140	148	156	164
PPV150LF 1-1/2"	10 GPM	73	100	120	134	147	159	168	177	185	192
PPV200LF 2"	12 GPM	106	148	182	205	230	244	256	266	274	280
Flow in Gallons per Minute (GPM)											
Valves should be sized based on a 5 to 10 PSI pressure drop											
Valve size will most likely be less than inlet / outlet pipe sizes											

*NOTE: The valve will maintain temperature with 0.0 GPM flow from the domestic hot water loop when properly installed near the hot water source with a continuously operating recirculation pump, see minimum flow for minimum pump flow rate

CAUTION! All thermostatic water mixing valves have limitations. They will NOT provide the desired accuracy outside of their flow capacity range. Consult the Flow Capacity Chart and DO NOT OVERSIZE. Minimum flow must be no less than as indicated.

NOTE: Flow rates will vary depending on existing field conditions. Leonard Valve Company always recommends using CASPAK® sizing software for proper valve sizing and model number applications.



1360 Elmwood Avenue, Cranston, RI 02910 USA
 Phone: 401.461.1200 Fax: 401.941.5310
 Email: info@leonardvalve.com
 Web Site: <http://www.leonardvalve.com>

PROTON PLUS DIMENSIONS

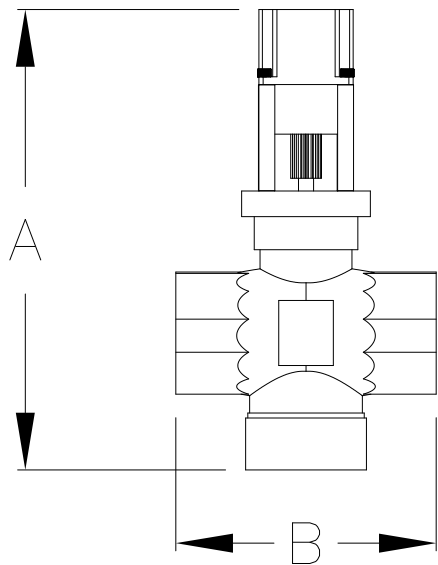

PPV LESS CHECK VALVES

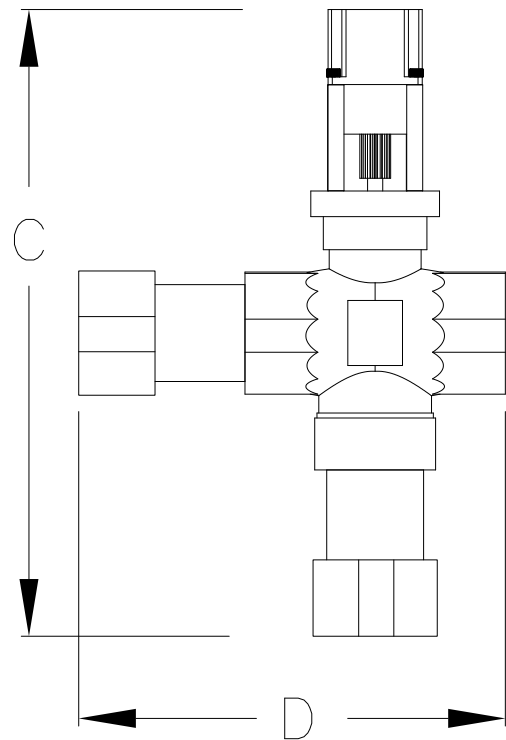

PPV WITH CHECK VALVES

✓	MODEL #	A	B	C	D
	PPV075LF	9"	3-1/4"	10"	4-1/2"
	PPV100LF	9-1/4"	4"	10-1/2"	5-1/2"
	PPV125LF	9-1/2"	4"	11-1/4"	5-3/4"
	PPV150LF	10"	4-3/4"	11-3/4"	6-1/2"
	PPV200LF	10-3/4"	5-1/2"	13-3/4"	8-1/4"

Dimensions are +/-1"



1360 Elmwood Avenue, Cranston, RI 02910 USA

Phone: 401.461.1200 Fax: 401.941.5310

Email: info@leonardvalve.com

Web Site: <http://www.leonardvalve.com>

