

# EMERGENCY MIXING VALVES

## Emergency Mixing Valve for Eye or Eye/Face Wash Units EXL-300-LF

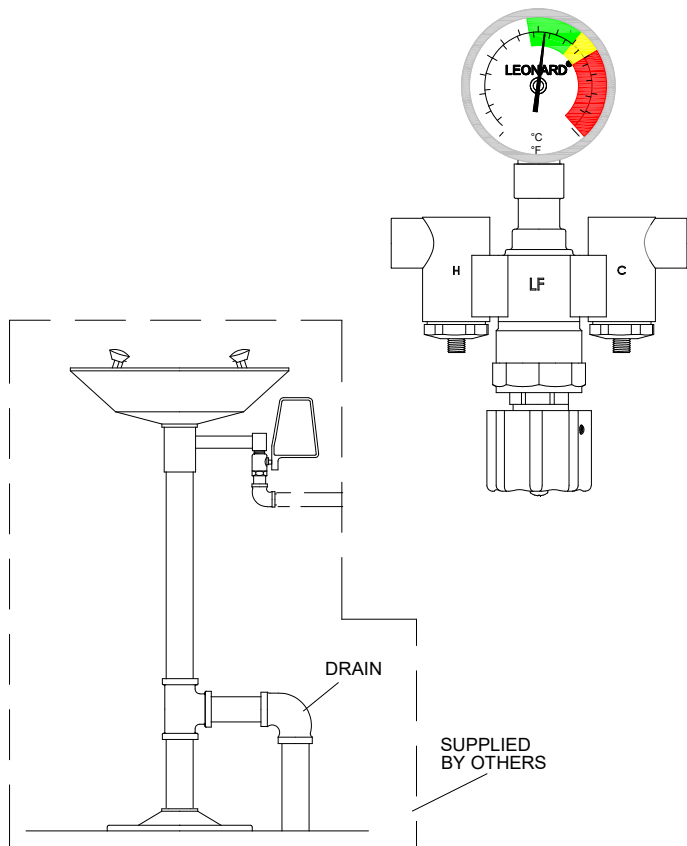

- High Performance Emergency Mixing Valve designed for eye or eye / face wash applications
- Thermostatic Mixing Valve can be set to the correct temperature for the application
- Mixing valve will close down on failure of cold water supply
- Mixing valve with special internal cold water bypass capable of a minimum of 7 GPM (26.5 l/min) @ 30 PSI (2.1 Bar) upon failure of hot water supply
- Adjustable high temperature limit stop \* set for 90°F (32°C)
- Locking temperature regulator to prevent accidental movement
- Integral Checkstops on inlets
- Threaded 1/2" side inlets
- Threaded 1/2" top or bottom outlet
- Rough bronze finish
- Dial thermometer (range 0 to 140°F, -18 to 60°C)
- Compliance.....ANSI Z358.1
- Maximum supply temperature 180 °F (82°C)
- Maximum supply pressure 125 PSI (8.6 Bar)

### OPTIONS:

- CP- Chrome plated finish
- IT- Inlet thermometers (shipped loose)
- ITP- Inlet temperature / pressure gauges (shipped loose)
- ILBV- Inlet locking ball valves (shipped loose)

### CABINET OPTIONS, SEE PAGE 3:

- SUFFIX BWE REC- Steel, baked white enamel recessed
- SUFFIX STSTL REC- Stainless Steel recessed cabinet
- SUFFIX BWE EXP- Steel, baked white enamel exposed
- SUFFIX STSTL EXP- Stainless Steel exposed cabinet
- SUFFIX TOP- Top inlets
- SUFFIX IT- Inlet thermometers on outside of exposed cabinets only and shipped loose
- SUFFIX ITP- Inlet temperature / pressure gauges on outside of exposed cabinets only and shipped loose

This product is certified to meet Low Lead requirements of wetted surface area containing less than 0.25% lead by weight



**WARNING:** Risk of cancer and reproductive harm from exposure to lead – See [www.P65Warnings.ca.gov](http://www.P65Warnings.ca.gov)

<b>Engineer's Approval</b>	Job # _____
	Arch/Eng. _____
	Contractor _____

\*NOTE: A limit stop, set for 90°F (32°C), is simply a mechanical setting to prevent excessive handle rotation. If incoming water is hotter than 135°F (57°C), the temperature of the factory test, the valve when turned to full HOT may deliver water in excess of 90°F and the limit stop MUST BE RESET BY THE INSTALLER

ASSE 1071 Certified



CSA Certified



1360 Elmwood Avenue, Cranston, RI 02910 USA

Phone: 401.461.1200 Fax: 401.941.5310

Email: [info@leonardvalve.com](mailto:info@leonardvalve.com)

Web Site: <http://www.leonardvalve.com>

# EMERGENCY WATER MIXING VALVE FOR EYE/FACE WASH

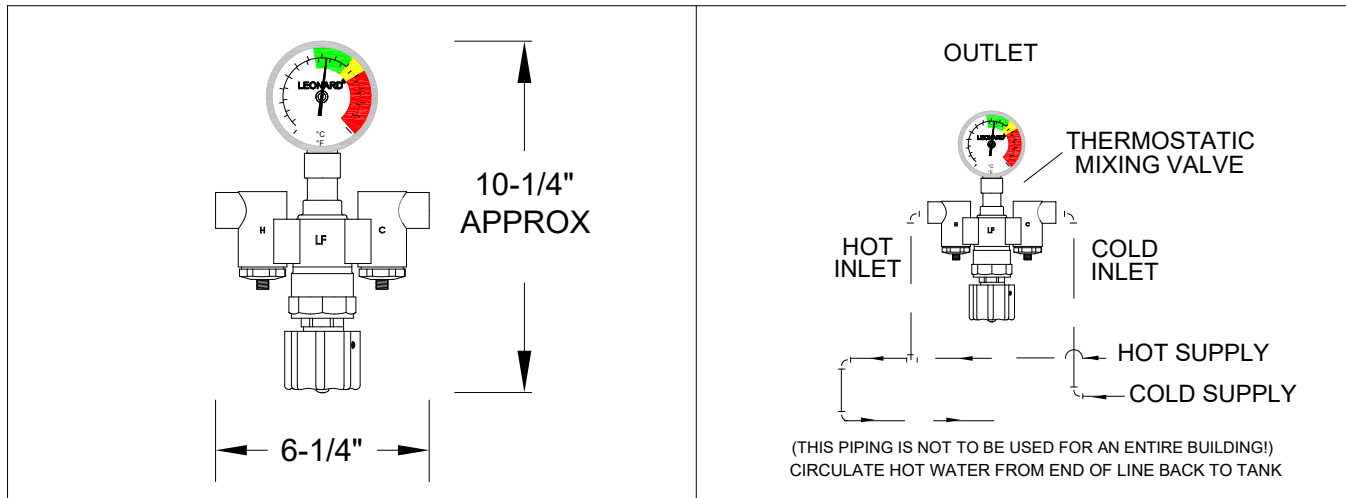

**CAUTION!** It may be necessary to recirculate the tempered water to the eye/face wash should the piping be exposed to excessive hot or cold conditions. Consult factory for proper piping.

## FLOW CAPACITIES

MODEL	IN	OUT	MINIMUM FLOW (GPM) L/MIN	INTERNAL COLD WATER BY-PASS AT 30 PSI DROP	PRESSURE DROP									PSI BAR
					5	10	15	20	25	30	35	40	45	
EXL-300-LF	1/2"	1/2"	2	7	3.5	7	8.5	10	11	12	12.5	13	13.5	GPM
			7.5	26.5	13.3	26.5	32.2	37.9	41.6	45.4	47.3	49.2	51.1	L/MIN
MAXIMUM FLOW CAPACITY														

The Emergency eye/face wash Mixing Valve shall control and maintain the temperature of the water to the station. Unit shall be self contained and include a thermostatic water mixing valve, a dial thermometer on the outlet, checkstops, unit set for 85°F (29°C) and a maximum temperature of 90°F (32°C). Unit must be able to be set to the correct temperature for the specific contaminant but must be locked in place to prevent changing of the temperature by accident. Unit must be checked weekly for performance in conjunction with the requirements of ANSI Z358.1.

**WARNING! IT IS THE RESPONSIBILITY OF THE SPECIFIER TO DETERMINE THE DELIVERED WATER TEMPERATURE TO EACH SAFETY FIXTURE. A COMFORTABLE RANGE IS 60°F TO 90°F (15° TO 32°C). IN CIRCUMSTANCES WHERE A CHEMICAL REACTION IS ACCELERATED BY WATER TEMPERATURE, A MEDICAL ADVISOR SHOULD BE CONSULTED FOR THE OPTIMUM TEMPERATURE FOR EACH APPLICATION.**

Specifications are subject to change without notice!

**CAUTION!** All thermostatic water mixing valves have limitations. They will NOT provide the desired accuracy outside of their flow capacity range. Consult the Flow Capacity Chart and DO NOT OVERSIZE. Minimum flow must be no less than indicated.



1360 Elmwood Avenue, Cranston, RI 02910 USA

Phone: 401.461.1200 Fax: 401.941.5310

Email: [info@leonardvalve.com](mailto:info@leonardvalve.com)

Web Site: <http://www.leonardvalve.com>

# EXL-300-LF-REC

## Designed to fit in a 2 X 4 wall viewport standard

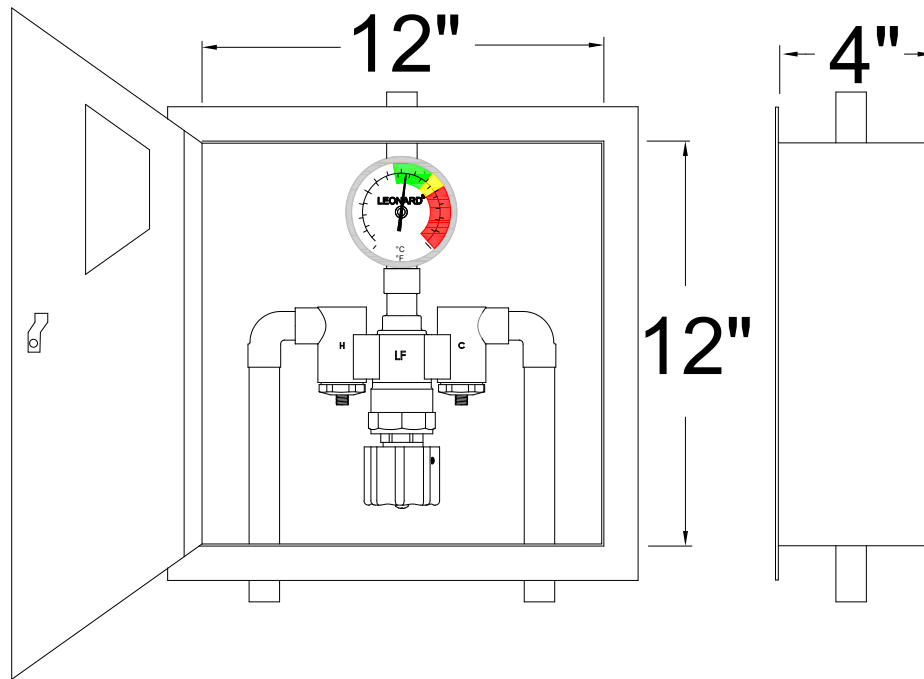

# EXL-300-LF-EXP

## viewport standard

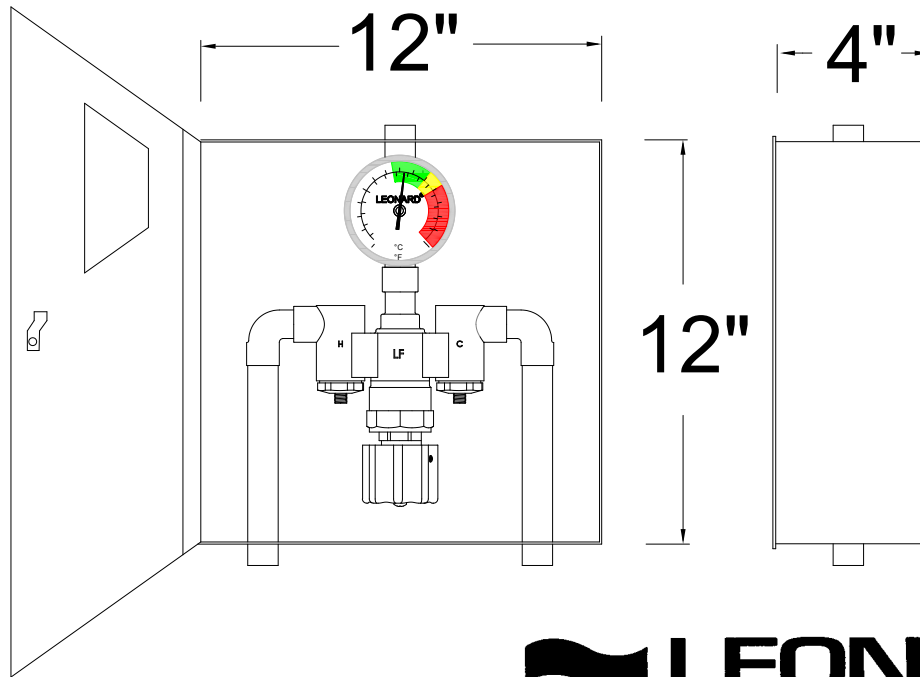

Note: Leonard Valve Company reserves the right of product, or design modifications without notice or obligation.

© 2026 Leonard Valve Company  
Printed in USA



1360 Elmwood Avenue, Cranston, RI 02910 USA

Phone: 401.461.1200 Fax: 401.941.5310

Email: [info@leonardvalve.com](mailto:info@leonardvalve.com)

Web Site: <http://www.leonardvalve.com>